

**functionality corresponding to flow module**  
**remote probe**  
**FCST-A4-NA/D100**

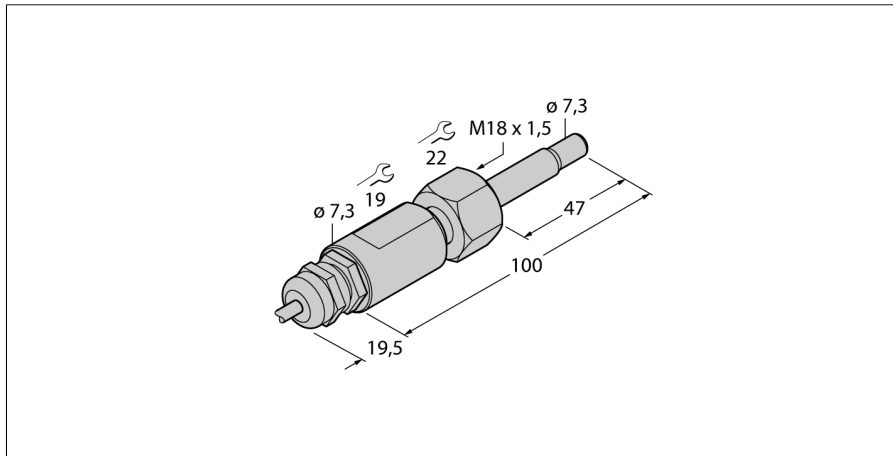

- Thermodynamic operating principle
- Functionality in accordance with flow module
- Extended temperature range
- Media temperature +10...120 °C
- Freely rotatable sensor
- Plugged in with adapter
- Screw-in adapter, M18 x 1.5

**Wiring diagram**

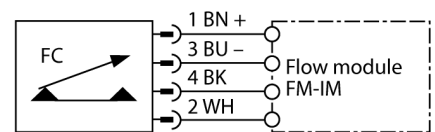

<b>Type code</b>	FCST-A4-NA/D100
Ident no.	6870267
<b>Operating range water</b>	1...150cm/s
Oil operating range	3...300 cm/s
Stand-by time	typ. 8 s (2...15 s)
Switch-on time	typ. 2 s (1...13 s)
Temperature gradient	≤ 250 K/min
Medium temperature	10...120 °C
<b>Protection class</b>	IP68
<b>Sensor material</b>	stainless steel, AISI 316Ti
Seal	FPM
Connection	FEP cable
Cable length	2 m
Cable cross section	4 x 0.25 mm <sup>2</sup>
Pressure resistance	100 bar
Process connection	M18 x 1.5 female thread

**Functional principle**

The FCST flow sensors operate on the thermodynamic principle.

Thanks to the modular plug-in concept, they can be aligned freely within the flow channel, independent from the process connection. The modular concept makes installation and precise alignment of the sensor easy which is very important for flow monitoring.

The adapters are available in all standard industrial thread sizes. The sensor-adapter system can thus be adjusted easily to any application requirements. The modular concept makes the system also very resistant to high pressures.

The remote probes are connected to the IO-link capable FM flow modules. With this, you can continuously monitor the flow velocity, medium temperature and collect diagnoses. Straightforward to use functionalities such as Quick-Teach, diagnostics, IO-Link transfer of process values and device parameters.

LEDs as well as a 10-segment LED band at the front indicate the local operating status.

**functionality corresponding to flow module**  
**remote probe**  
**FCST-A4-NA/D100**

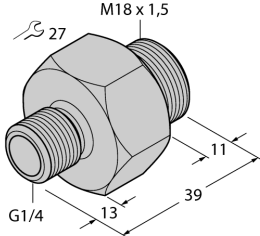
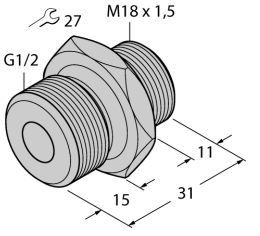
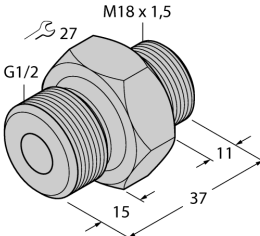
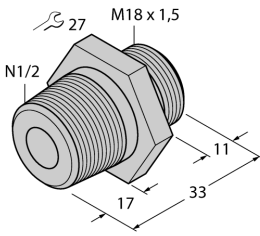
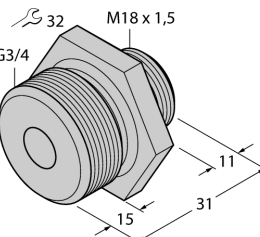
	<p>Optionally available Screw-in adapter, stainless steel, M18 x 1.5 on G1/4 FCA-FCST-G1/4-A4 Ident-no. 6870290</p>	
	<p>Optionally available Screw-in adapter, stainless steel, M18 x 1.5 on G1/2 FCA-FCST-G1/2-A4 Ident-no. 6870291</p>	
	<p>Optionally available Screw-in adapter, stainless steel, M18 x 1.5 on G1/2 FCA-FCST-G1/2-A4/L037 Ident-no. 6870292</p>	
	<p>Optionally available Screw-in adapter, stainless steel, M18 x 1.5 on N1/2 FCA-FCST-N1/2-A4 Ident-no. 6870293</p>	
	<p>Optionally available Screw-in adapter, stainless steel, M18 x 1.5 on G3/4 FCA-FCST-G3/4-A4 Ident-no. 6870294</p>	

functionality corresponding to flow module  
remote probe  
FCST-A4-NA/D100

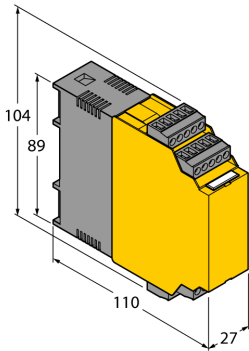

Optionally available  
Flow module  
FM-IM-3UP63X  
Ident no. 7525100

Wiring diagram

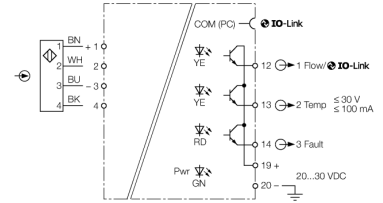

Optionally available  
Flow module  
FM-IM-3UR38X  
Ident no. 7525102

Wiring diagram

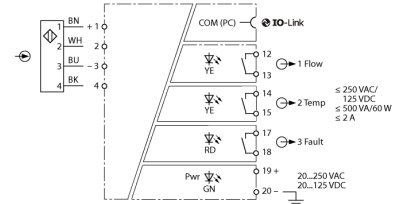

Optionally available  
Flow module  
FM-IM-2UPLi63X  
Ident no. 7525104

Wiring diagram

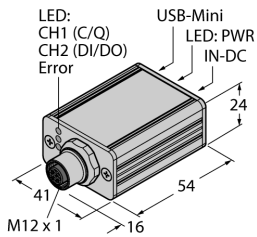
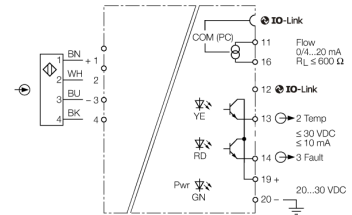

Optionally available  
IO-Link master 1.1 with integrated USB port  
USB-2-IOL-0002  
Ident no. 6825482

Wiring diagram

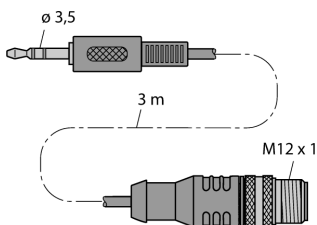
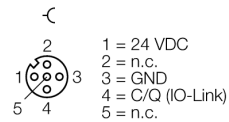

Optionally available  
Connection between FM-IM and IO-Link master  
IOL-COM/3M  
Ident-no. 7525110

Wiring diagram

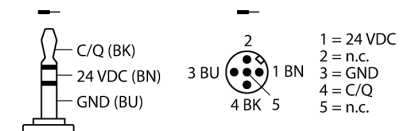

**functionality corresponding to flow module**  
**remote probe**  
**FCST-A4-NA/D100**

**LED display**

LED	Color	Status	Description
			Depending on the flow module used

**Mounting instructions**

Mounting adapter	<p>The freely rotatable flow sensors are mounted with the FCA-FCST adapter. The adapter is screwed in a T-piece or a welding sleeve and sealed accordingly. When assembling adapters with cylindrical thread, use the enclosed seal (e.g. G1/4, G1/2, G3/4, etc.). Mounting adapters with NPT-thread are generally delivered without seal (e.g. N1/2). Use hemp or teflon tape</p> <p>The sensor is fixed in the adapter by means of a captive nut fitted between the upper housing part and the cone seat.</p>
Mounting position	<p>In order to minimize potential misinterpretations due to disturbance, it is recommended to position the sensor with a minimum separation distance of 3 x di before and 5 x di after bends, changes in cross section, valves, etc..</p> <ul style="list-style-type: none"> <li>■ If the flow channel is not completely filled with the medium, it is recommended to install the sensor from underneath.</li> <li>■ If deposits are likely to built up, it is recommended to install the sensor on the side. It is important to note that deposits can also form on the tip, which may affect the monitoring results. Therefore, it is recommended to clean the sensor at regular intervals and to select the associated service interval accordingly.</li> <li>■ If blistering is to be expected, ensure that there is no air bubble located in the area of the tip when installing the sensor.</li> <li>■ If the sensor is mounted in vertical piping systems, it is recommended to position the sensor within the riser.</li> </ul>
Correct installation	<p>To retrieve the full performance potential of the sensor, it must be aligned correctly. In particular when monitoring bad heat-conductive media such as oils, liquids with high solids, abrasive media, etc., when exposed to fast temperature changes (K/min) and, in general, near components with analog output.</p> <p>Correct installation is ensured, as soon as the effective flow direction of the application matches the direction of flow indicated by the "arrow" on the sensor.</p>