

Flow sensor
Immersion sensor without integrated processor
FCS-68A4-NA/D003

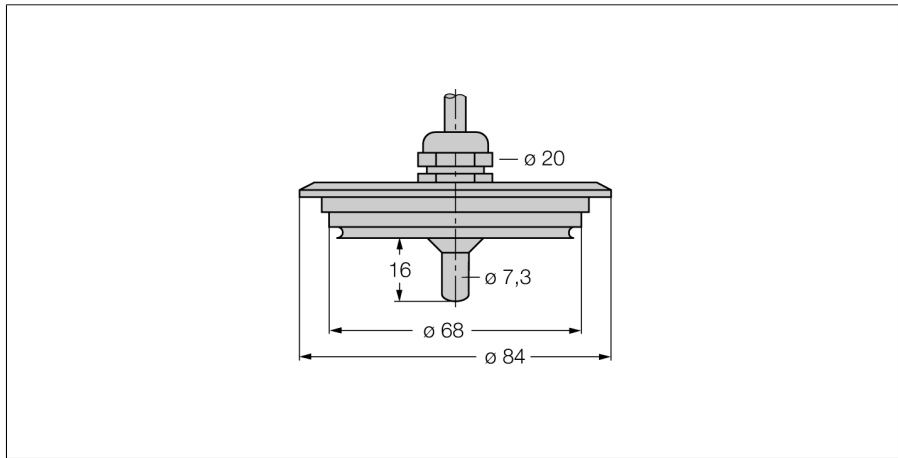

- Flow sensor for liquid media
- Calorimetric principle
- Adjustment via potentiometer on processor
- Status indicated via LED chain on signal processor
- Temperature range: +10...+120 °C
- Mechanical Connection: Varivent
- Cable device
- 4-wire connection to the processor

Wiring diagram

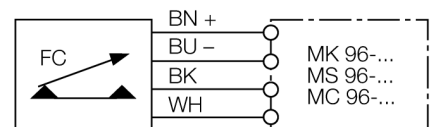

Functional principle

Our insertion - flow sensors operate on the principle of thermodynamics. The measuring probe is heated by several °C as against the flow medium. When fluid moves along the probe, the heat generated in the probe is dissipated. The resulting temperature is measured and compared to the medium temperature. The flow status of every medium can be derived from the evaluated temperature difference. Thus TURCK's wear-free flow sensors reliably monitor the flow of gaseous and liquid media.

Type code	FCS-68A4-NA/D003
Ident no.	6872044
Operating range water	1...150cm/s
Oil operating range	3...300 cm/s
Stand-by time	typ. 8 s (2...15 s)
Switch-on time	typ. 2 s (1...15 s)
Switch-off time	typ. 2 s (1...15 s)
Temperature jump, response time	max. 12 s
Temperature gradient	≤ 250 K/min
Medium temperature	10...120 °C
Ambient temperature	-20...80 °C
Protection class	IP68
Housing material	stainless steel, V4A (1.4571)
Sensor material	stainless steel, AISI 316Ti
Connection	PVC cable
Cable length	2 m
Cable cross section	4 x 0.25 mm ²
Pressure resistance	10 bar
Process connection	Varivent