

Flow sensor
Inline sensor with separate processor
FCI-D03A4P-NA

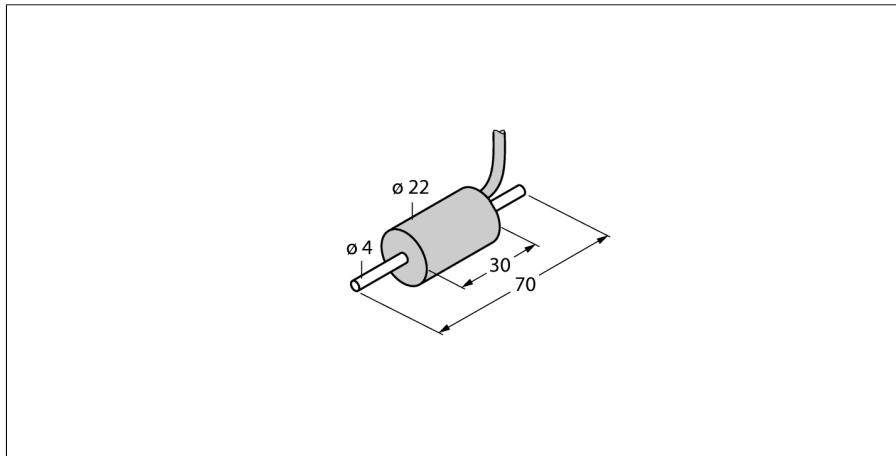

- Flow sensor for liquid media
- Calorimetric principle
- Adjustment via potentiometer on processor
- Status indicated via LED chain on signal processor
- Sensor housing made of Delrin
- Mechanical Connection: Barrel, 4 mm
- Cable device
- 4-wire connection to the processor

Wiring diagram

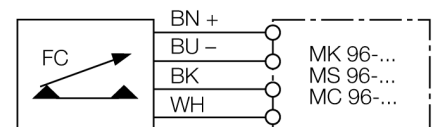

Functional principle

The function of the inline flow sensors is based on the thermo-dynamic principle. Heat is generated in a measuring tube and absorbed by the flowing medium. The transported heat loss is thus a measure of the flow speed. Thus TURCK's wear-free flow sensors reliably monitor the flow of gaseous and liquid media. A low pressure drop and fast response to flow rate variations are the outstanding features of these devices.

Type code	FCI-D03A4P-NA
Ident no.	6870637
Flow operating range	0,005...0,15 l/min.
Oil operating range	15...300ml/min
Stand-by time	typ. 8 s (2...15 s)
Switch-on time	typ. 2 s (1...15 s)
Switch-off time	typ. 2 s (1...15 s)
Temperature jump, response time	max. 12 s
Temperature gradient	≤ 250 K/min
Medium temperature	- 5...70 °C
Protection class	IP68
Housing material	plastic, Delrin
Sensor material	stainless steel, AISI 316Ti
Connection	PVC cable
Cable length	2 m
Cable cross section	4 x 0.25 mm ²
Pressure resistance	5 bar
Process connection	Tube 4 mm