

Flow sensor
Inline sensor with integrated processor
FCI-D04A4P-ARX-H1140

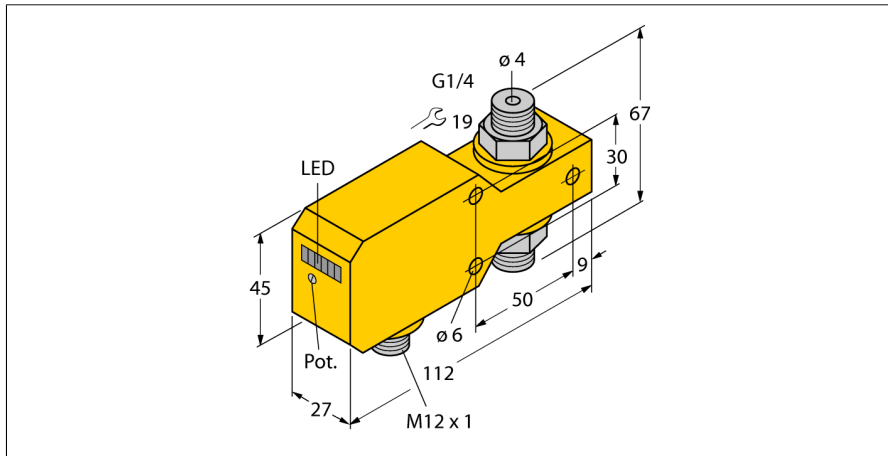

- Flow sensor for liquid media
- Calorimetric principle
- Adjustment via potentiometer
- LED band
- Operating range 0.01...1 l/min
- 4-wire DC, 21...26 VDC
- NO contact, relay output
- Plug-in device, M12 x 1

Wiring diagram

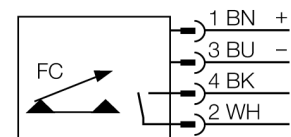

Functional principle

The function of the inline flow sensors is based on the thermo-dynamic principle. Heat is generated in a measuring tube and absorbed by the flowing medium. The transported heat loss is thus a measure of the flow speed. Thus TURCK's wear-free flow sensors reliably monitor the flow of gaseous and liquid media. A low pressure drop and fast response to flow rate variations are the outstanding features of these devices.

Type code	FCI-D04A4P-ARX-H1140
Ident no.	6870645
Flow operating range	0,01...1 l/min.
Stand-by time	5...15 s
Switch-on time	0.5...1 s
Switch-off time	0.5...1 s
Temperature gradient	≤ 400 K/min
Medium temperature	- 20...80 °C
Ambient temperature	0...60 °C
Operating voltage	21...26VDC
No-load current I ₀	≤ 50 mA
Output function	Relay output, NO contact
Rated operational current	1 A
Short-circuit protection	no
Reverse polarity protection	yes
AC switching voltage	30 VAC
DC switching voltage	36 VDC
Housing material	plastic, PBT
Sensor material	stainless steel, AISI 316Ti
Max. tightening torque housing nut	100 Nm
Connection	male, M12 x 1
Pressure resistance	20 bar
Process connection	G 1/4"
Switching state	LED chain green / yellow / red
Flow state display	LED chain, red (1x), green (5x)
Indication: Drop below setpoint	LED red
Indication: Setpoint reached	LED yellow
Indication: Setpoint exceeded	4 x LEDs green
LED display	red = 4 mA
	1 x green > 4 mA
	2 x green > 8 mA
	3 x green > 12 mA
	4 x green > 16 mA
	5 x green = 20 mA