

**Flow sensor**  
**Inline sensor with integrated processor**  
**FCI-D20A4P-ARX-H1140**

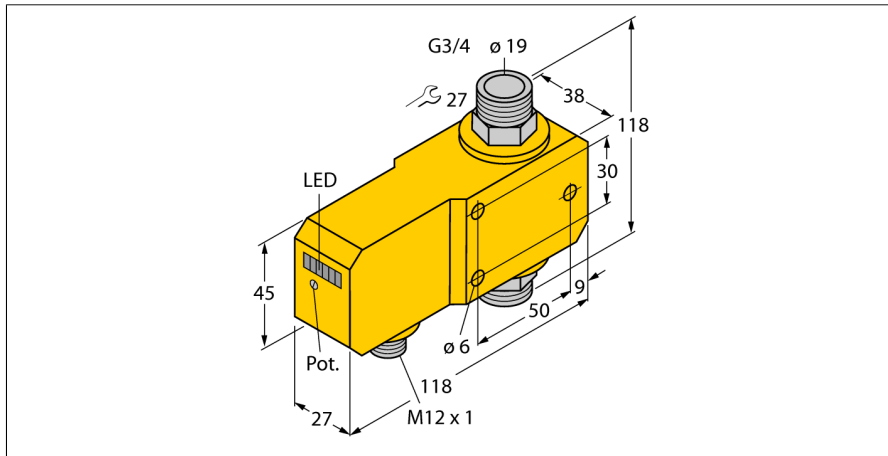

- Flow sensor for liquid media
- Calorimetric principle
- Adjustment via potentiometer
- LED band
- Operating range 4...30 l/min
- 4-wire DC, 21...26 VDC
- NO contact, relay output
- Plug-in device, M12 x 1

**Wiring diagram**

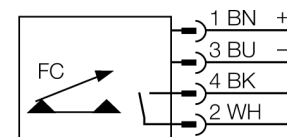

**Functional principle**

The function of the inline flow sensors is based on the thermo-dynamic principle. Heat is generated in a measuring tube and absorbed by the flowing medium. The transported heat loss is thus a measure of the flow speed. Thus TURCK's wear-free flow sensors reliably monitor the flow of gaseous and liquid media. A low pressure drop and fast response to flow rate variations are the outstanding features of these devices.

<b>Type code</b>	FCI-D20A4P-ARX-H1140
<b>Ident no.</b>	6870674
<b>Flow operating range</b>	4...30 l/min.
Stand-by time	5...15 s
Switch-on time	0.5...1 s
Switch-off time	0.5...1 s
Temperature gradient	≤ 400 K/min
Medium temperature	- 20...80 °C
Ambient temperature	0...60 °C
<b>Operating voltage</b>	21...26VDC
No-load current I <sub>0</sub>	≤ 50 mA
Output function	Relay output, NO contact
Rated operational current	1 A
Short-circuit protection	no
Reverse polarity protection	yes
AC switching voltage	30 VAC
DC switching voltage	36 VDC
<b>Housing material</b>	plastic, PBT
Sensor material	stainless steel, AISI 316Ti
Max. tightening torque housing nut	100 Nm
Connection	male, M12 x 1
Pressure resistance	20 bar
Process connection	G 3/4"
<b>Switching state</b>	LED chain green / yellow / red
Flow state display	LED chain, red (1x), green (5x)
Indication: Drop below setpoint	LED red
Indication: Setpoint reached	LED yellow
Indication: Setpoint exceeded	4 x LEDs green
LED display	red = 4 mA
	1 x green > 4 mA
	2 x green > 8 mA
	3 x green > 12 mA
	4 x green > 16 mA
	5 x green = 20 mA