



Features

- Low cost and easy to use; no adjustments are necessary
- Models available for opposed (through-beam), retroreflective, polarized retroreflective, diffuse and fixed-field modes
- Advanced self-diagnostics with separate alarm output; dual LED system indicates sensor performance
- 5-pin quick-disconnect connector for DeviceNet-compatible cable
- Epoxy-encapsulated circuitry; leakproof IP67 (NEMA 6P) rating for harsh sensing environments
- Brackets available for several mounting options

Sensing Mode Options



Description

T18XDN Series EZ-BEAM sensors are designed specifically for use on DeviceNet™ Bus Networks. These are smart sensors which can be wired directly to a DeviceNet bus using a "dumb" tee.

T18XDN Series sensors offer all of the features and powerful sensing performance that EZ-BEAMs offer. The innovative dual-indicator system takes the guesswork out of sensor performance monitoring. Housings are tightly sealed and the sensor circuitry is epoxy-encapsulated for reliable duty in wet or oily sensing environments. Models are available for opposed (through-beam), retroreflective, polarized retroreflective, diffuse and fixed-field sensing.

Several mounting options are offered, including angled brackets and split-clamp brackets. T18XDN series sensors may also be simply mounted through suitable clearance holes. See page 5 for more information.

†U.S. Patent #5087838



WARNING . . . Not To Be Used for Personnel Protection

Never use this product as a sensing device for personnel protection. Doing so could lead to serious injury or death.

This product does NOT include the self-checking redundant circuitry necessary to allow its use in personnel safety applications. A sensor failure or malfunction can cause either an energized or de-energized sensor output condition. Consult your current Banner Safety Products catalog for safety products which meet OSHA, ANSI and IEC standards for personnel protection.



Infrared, 950 nm

Opposed-Mode Emitter (E) and Receiver (R) Models

Models	Range	Cable	Supply Voltage	Change of State	Excess Gain	Beam Pattern
T18XDN1EQ6	20 m (66 ft)	5-pin Euro QD	11-25V dc	—		
T18XDN1RQ6				Bit 0 output: 0 = Off 1 = On Bit 1 Alarm: 0 = Off 1 = On Bit 2-7: Not Used		



Visible red, 680 nm, Polarized

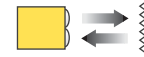

Infrared, 950 nm, Non-Polarized

Retroreflective Mode Models

Models	Range	Cable	Supply Voltage	Change of State	Excess Gain	Beam Pattern
T18XDN1LPQ6	2 m (79 in)	5-pin Euro QD	11-25V dc	Bit 0 output: 0 = Off 1 = On Bit 1 Alarm: 0 = Off 1 = On Bit 2-7: Not Used		
T18XDN1LQ6	2 m (79 in)	5-pin Euro QD	11-25V dc	Bit 0 output: 0 = Off 1 = On Bit 1 Alarm: 0 = Off 1 = On Bit 2-7: Not Used		

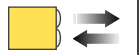

Infrared, 880 nm

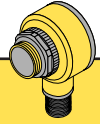

Diffuse Mode Models

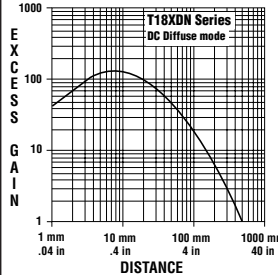
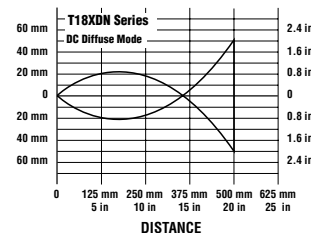
Models	Range	Cable	Supply Voltage	Change of State	Excess Gain	Beam Pattern
					Performance based on 90% reflectance white test card	
T18XDN1DQ6	500 mm (20 in)	5-pin Euro QD	11-25V dc	Bit 0 output: 0 = Off 1 = On Bit 1 Alarm: 0 = Off 1 = On Bit 2-7: Not Used		

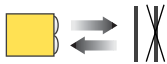

Infrared, 880 nm

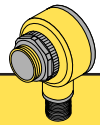

Fixed-Field Mode Models

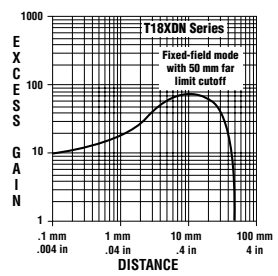
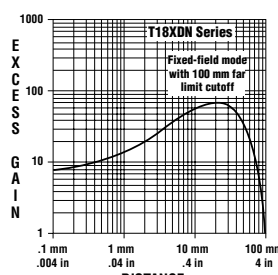
Models	Range	Cable	Supply Voltage	Change of State	Excess Gain
					Performance based on 90% reflectance white test card
50 mm far limit cutoff					
T18XDN1FF50Q6	50 mm (2 in)	5-pin Euro QD	11-25V dc	Bit 0 output: 0 = Off 1 = On Bit 1 Alarm: 0 = Off 1 = On Bit 2-7: Not Used	
100 mm far limit cutoff					
T18XDN1FF100Q6	100 mm (4 in)	5-pin Euro QD	11-25V dc	Bit 0 output: 0 = Off 1 = On Bit 1 Alarm: 0 = Off 1 = On Bit 2-7: Not Used	



T18XDN Series

Specifications									
Supply Voltage and Current	11 to 25V dc (10% maximum ripple); Supply current (exclusive of load current): Opposed Mode Emitter: 25 mA Opposed Mode Receiver: 45 mA Polarized & Non Polarized Retro: 55 mA Diffuse: 55 mA Fixed-Field: 60 mA								
Supply Protection Circuitry	Protected against reverse polarity and transient voltages								
Output Protection Circuitry	Protected against false pulse on power-up and continuous overload or short-circuit of outputs								
Output Response Time	Opposed: 3.5 milliseconds ON and 2.0 milliseconds OFF Polarized Retro and Fixed-Field: 3.5 milliseconds ON and OFF <i>NOTE: 100 millisecond delay on power-up; outputs do not conduct during this time.</i>								
Repeatability	Opposed: 575 microseconds Polarized Retro and Fixed-Field: 950 microseconds Repeatability and response are independent of signal strength								
Indicators	Two LEDs: a bi-colored (Red/Green) LED and a Yellow LED A bi-color LED indicates the status of the network: Green ON Steady = Sensor on line, connected to master Green Flashing = Sensor on line, address + baud rate are ok Red ON Steady = Critical network fault or duplicate node address detected; wrong baud rate Red Flashing = Minor or connection time-out fault Yellow ON Steady = Normally open output is conducting Yellow Flashing = Excess gain marginal (1-1.5x) in light condition								
Sensor Configuration	The following features of the T18XDN Series Sensors are programmable via the network with a configuration tool: <table border="0" style="width: 100%;"> <thead> <tr> <th style="text-align: left;">Feature</th> <th style="text-align: left;">Range (default)</th> </tr> </thead> <tbody> <tr> <td>Network Address</td> <td>0-63 (63)</td> </tr> <tr> <td>Baud Rate</td> <td>125K, 250K, 500K (125K)</td> </tr> <tr> <td>Operation Mode</td> <td>Light Operate or Dark Operate (Light Operate)</td> </tr> </tbody> </table> All T18XDN models support: Explicit Message Connection: Required to <i>Set</i> and <i>Get</i> sensor <i>Attributes</i> Change of State Connection (COS): which responds to a slave's change of state. I/O Response is with the following 8-bit word of data: Bit 0: 0 Output is OFF 1 Output is ON Bit 1: 0 Alarm output is OFF 1 Alarm output is ON Bits 2-7 Not Used: Always 0 <i>Note: Configuration may be simplified through use of an Electronic Data Sheet (Banner model EDS 40223)</i>	Feature	Range (default)	Network Address	0-63 (63)	Baud Rate	125K, 250K, 500K (125K)	Operation Mode	Light Operate or Dark Operate (Light Operate)
Feature	Range (default)								
Network Address	0-63 (63)								
Baud Rate	125K, 250K, 500K (125K)								
Operation Mode	Light Operate or Dark Operate (Light Operate)								
Construction	Housings are PBT thermoplastic polyester; lenses are polycarbonate (opposed models) or acrylic (retro and fixed-field models); T18XDN comes with one jam nut								
Environmental Rating	Leakproof design rated NEMA 6P; IEC IP67								
Connections	5-pin Euro-style DeviceNet compatible quick-disconnect fitting; cables are ordered separately - interlinkBT								
Operating Temperature	-25° to +70°C (-13° to 158°F); Maximum relative humidity 90% at 50°C (non-condensing)								
Vibration and Mechanical Shock	All models meet Mil. Std. 202F requirements. Method 201A (Vibration; frequency 10 to 60 Hz, max., double amplitude 0.06-inch acceleration 10G). Method 213B conditions H&I (Shock: 75G with unit operating; 100G for non-operation)								

Dimensions

T18XDN (All models except emitter)

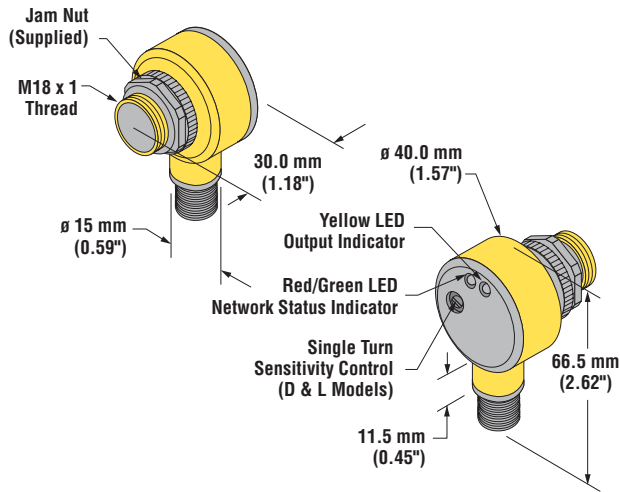

T18XDN Emitter

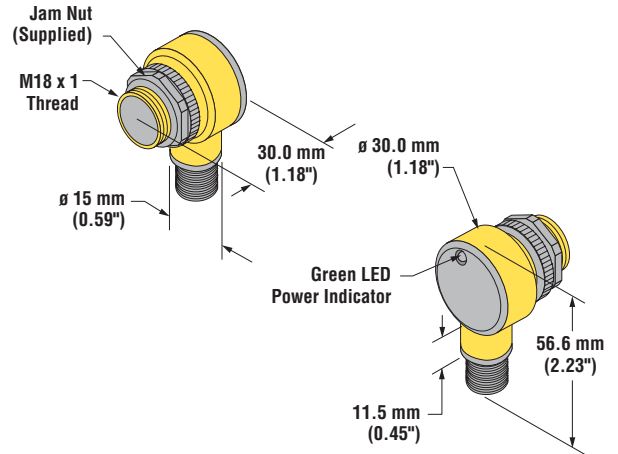

Hookups

Quick Disconnect Pin Detail (Except Emitter) connector on sensor shown (male pins)

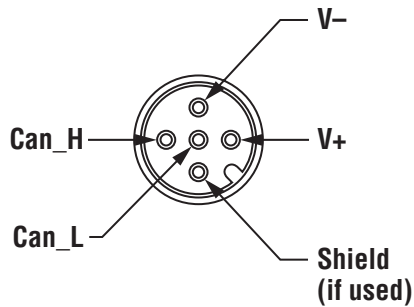

Emitter Quick Disconnect Pin Detail connector on sensor shown (male pins)

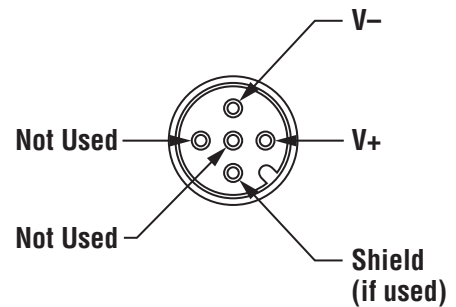

The T18XDN Series sensor requires DeviceNet-compatible quick-disconnect cable, which is available from various manufacturers, such as interlinkBT.

Mounting Brackets

<p>SMB18A</p>	<ul style="list-style-type: none"> • For use with M18, S18, S186ELD, T18 and Q25 Series sensors • 12-gauge, stainless steel, right angle mounting bracket with a curved mounting slot for versatility and orientation • Clearance for M4 (#8) hardware 	<p>SMB18C</p>	<ul style="list-style-type: none"> • For use with S18, M18, T18 and Q25 Series sensors • 18 mm split clamp bracket • Black thermoplastic polyester • Includes stainless steel mounting hardware
----------------------	---	----------------------	---

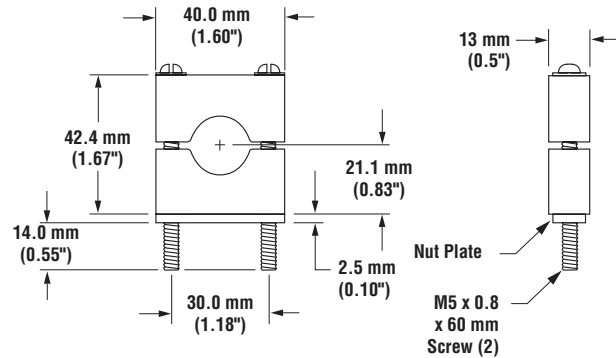
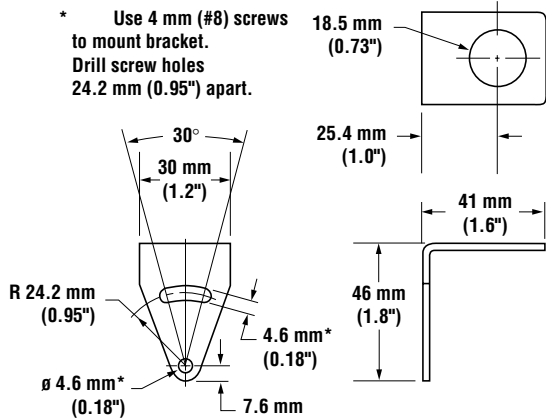
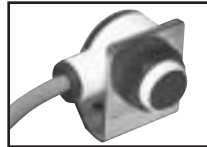

<p>SMB18S</p>	<ul style="list-style-type: none"> • 18 mm swivel bracket • black thermoplastic polyester • Includes stainless steel mounting hardware
----------------------	---

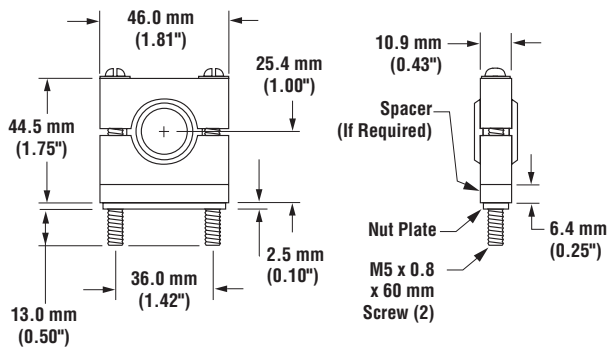
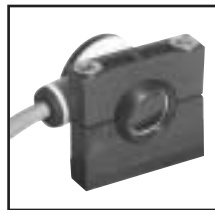

more sensors, more solutions

WARRANTY: Banner Engineering Corp. warrants its products to be free from defects for one year. Banner Engineering Corp. will repair or replace, free of charge, any product of its manufacture found to be defective at the time it is returned to the factory during the warranty period. This warranty does not cover damage or liability for the improper application of Banner products. This warranty is in lieu of any other warranty either expressed or implied.