



L-GAGE™ Laser Gauging Sensor – 75 to 125 mm Range

Class 2 visible laser displacement sensor with both analog and discrete (switched) outputs



L-GAGE LG10 Series Laser Gauging Sensor Features

- Self-contained Class 2 modulated visible laser gauging sensor needs no separate controller
- Narrow effective beam is excellent for precision gauging applications or for distance, height, or thickness measurement
- Resolution to better than 25 microns
- Sensing window may be sized as needed, and placed anywhere within the 75.0 to 125.0 millimeter (2.95" to 4.92") sensing distance; 5 mm (0.2") minimum window size
- Banner's unique scalable analog output (patent pending) automatically distributes the output signal over the width of the programmed sensing window
- Analog and discrete (switched) outputs
- Window limits for analog and discrete outputs may be set independently
- Analog output slope is either positive or negative, depending upon which window limit is programmed first
- Fast, easy-to-use integrated push-button TEACH-mode programming; no potentiometer adjustments
- Remote TEACH function for security and convenience
- Unique feature holds analog output value for 2 seconds upon loss of signal
- Modulated laser beam and narrow optical band-pass filter provide a high level of ambient light immunity, including immunity from high-energy factory lighting
- Alarm output for signal saturation
- Output response is programmable for three speeds
- 12 to 30V dc operation
- Enclosure rated IEC IP67; NEMA 6

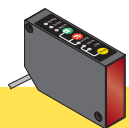

L-GAGE LG10 Series Laser Gauging Sensor Models

Models	Sensing Distance	Focal Point†	Cable*	Supply Voltage	Discrete Output	Analog Output
LG10A65NI	75.0 to 125.0 mm (2.95" to 4.92")	180 mm (7.1") Beam size at 125 mm: 0.6 x 0.8 mm (0.024" x 0.031")	2 m (6.5') 8-wire	12 to 30V dc	NPN (sinking)	Analog current output (4 to 20 mA)
LG10A65PI					PNP (sourcing)	

* NOTE: 9 m (30') cables are available by adding suffix "W/30" to the model number of any cabled sensor (e.g., **LG10A65NI W/30**)

† The Focal Point is the distance measured from the lens (front of sensor) at which the diameter of the laser image is smallest.

L-GAGE™ LG10 Series Laser Gauging Sensor

L-GAGE Laser Gauging Sensor Overview

Banner's Class 2 visible laser displacement sensor brings a sophisticated yet cost-effective solution to precision measurement applications. L-GAGE Series sensors feature all-in-one design and require no separate controller.

Near and far sensing window limits are set quickly using simple push-button or remote signal TEACH-mode programming. One sensor can simultaneously provide both analog and discrete (switched) outputs. Sensing window limits for each output may be independently programmed. The analog signal features Banner's unique scalable output (patent pending), which automatically distributes the 4 to 20 milliamp output signal over the width of the programmed sensing window. If an analog voltage output is required, this can be accomplished by using an alternate hookup. (See Hookups, page 5.)

The L-GAGE Laser Gauging Sensor boasts many additional features, including selectable response speed, self-diagnostics with alarm output, comprehensive status indicator system, and unique output "hold" function in case of momentary signal loss in profiling applications.

Optical Triangulation

The design of the L-GAGE Laser Gauging Sensor is based on optical triangulation (see figure 1). An emitter transmits visible laser light through a lens, toward a target. The laser light beam from the emitter bounces off the target, scattering some of its light through another lens to the sensor's PSD (position-sensitive device) receiver element. The target's distance from the receiver determines the angle the light travels to the receiver element; this angle in turn determines where the received light will fall along the PSD receiver element.

The position of the light on the PSD receiver element is processed through analog and digital electronics and analyzed by the microprocessor, which calculates the appropriate output value. The analog output provides a variable 4 to 20 milliamp current that is proportional to the target's position within the user-programmed analog window limits (see page 8). The discrete (switched) output energizes whenever the target is located between the user-programmed discrete window limits. Analog and discrete window limits may be the same, or programmed independently.

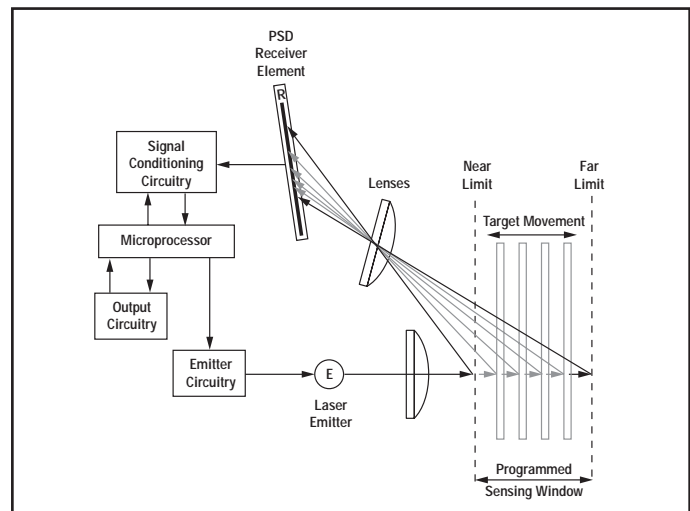

Figure 1. Optical triangulation sensing system overview

L-GAGE™ LG10 Series Laser Gauging Sensor

L-GAGE LG10 Series Laser Gauging Sensor Specifications

Sensing Range	75.0 to 125.0 mm (2.95" to 4.92")
Supply Voltage	12 to 30V dc, (10% maximum ripple); 50 mA max at 24V dc (exclusive of load)
Supply Protection Circuitry	Protected against reverse polarity, over voltage, and transient voltages
Delay at Power-up	1.25 second
Sensing Beam	670 nm visible red IEC and CDRH Class 2 laser; 0.15 mW radiant output power
Output Configurations	Discrete (switched) output: SPST solid-state switch; choose NPN (current sinking) or PNP (current sourcing) models Analog output: 4 to 20 milliamp current sourcing Alarm output: SPST solid-state switch; NPN (current sinking) or PNP (current sourcing), depending on discrete output model
Output Ratings	Discrete (switched) and Alarm output: 100 mA maximum Off-state leakage current: less than 5 microamps Output saturation voltage (PNP output): less than 1.2 volts at 10 mA and less than 1.6 volts at 100 mA Output saturation voltage (NPN output): less than 200 millivolts at 10 mA and less than 600 millivolts at 100 mA Analog output: 1 kΩ max @ 24V dc; max load resistance = $\left[\frac{V_{CC} - 4.5}{0.02} \Omega \right]$
Output Protection	Outputs are protected against continuous overload and short circuit
Output Response Time	Discrete Output: Fast: 3.6 milliseconds ON and OFF Medium: 10 milliseconds ON and OFF Slow: 40 milliseconds ON and OFF Analog Output (-3 dB): Fast: 250 Hz (1.6 milliseconds average with 1.6 millisecond update rate) Medium: 40 Hz (10 milliseconds average with 1.6 millisecond update rate) Slow: 10 Hz (40 milliseconds average with 2.1 millisecond update rate)
Analog Resolution and Repeatability of Discrete Trip Point*	Fast: <150 microns @ 100 mm Medium: <50 microns @ 100 mm Slow: <25 microns @ 100 mm See Figure 3, page 4.
Analog Linearity*	± 200 microns (±0.008") over 75 to 125 mm sensing window ± 20 microns (±0.0008") over 95 to 100 mm sensing window
Minimum Window Size (Analog or Discrete)	5 mm (0.2")
Hysteresis (Discrete Output)	<1 mm
Color Sensitivity*	<100 microns (0.004") (typical) for white to dark gray ceramic target
Temperature Drift	±25 microns/°C
Remote TEACH and Laser Control Input Impedance	18 kΩ minimum (65 kΩ minimum at 5V)
Laser Control	Connect green wire to +5 to 30V dc to enable laser beam; connect to 0 to +2V dc (or open connection) to disable; 250 millisecond delay upon enable.
Remote TEACH	Connect yellow wire to +5 to 30V dc to teach; connect to 0 to +2V dc (or open connection) to disable; see Remote Programming page 7.
Adjustments	Response speed: push button toggles between 1.6, 10, and 40 milliseconds Window limits (analog or discrete): TEACH-mode programming of near and far window limits (see programming procedure). Limits may also be taught remotely via TEACH input (see page 7). Analog output slope: the first limit taught is assigned to minimum output current (4mA).

*Using white ceramic test surface (see Application Notes). Resolution and linearity specified at 24V dc, 22°C.

L-GAGE™ LG10 Series Laser Gauging Sensor

L-GAGE LG10 Series Laser Gauging Sensor Specifications (continued)

Indicators	<p>Green Power ON LED: Indicates when power is ON, overloaded output and laser status.</p> <p>Yellow Output LED: Indicates when discrete load output is conducting.</p> <p>Red Signal LED: Indicates when target is within sensing range and the condition of the received light signal.</p> <p>Tri-color Red/Green/Yellow TEACH LED: Indicates sensor is ready for programming each limit (indicates red for analog output, green for discrete, and yellow for simultaneous analog and discrete.)</p> <p>Yellow Fast/Slow LEDs: Combination of 2 lights ON or OFF indicates 1 of 3 response speeds.</p> <p>NOTE: See page 5 for more information on indicator behavior.</p>
Construction	<p>Housing: Zinc alloy die-cast, plated and painted finish</p> <p>Cover plate: aluminum with painted finish</p> <p>Lens: acrylic</p>
Environmental Rating	IP67, NEMA 6
Connections	2 m (6.5') or 9 m (30') 7-conductor shielded PVC-jacketed attached cable.
Operating Conditions	<p>Temperature: -10° to +50° C (+14° to 122° F)</p> <p>Maximum relative humidity: 90% at 50° C, non-condensing</p>
Vibration and Mechanical Shock	<p>Vibration: 60 Hz, 30 minutes, 3 axes</p> <p>Shock: 30G for 11 milliseconds, half sine wave, 3 axes</p>
Application Notes	For comparison, a white ceramic test surface has approximately 91% of the reflectivity of a white Kodak test card with a matte finish. A dark gray ceramic test surface has approximately 11% of the reflectivity of a white Kodak test card with a matte finish.

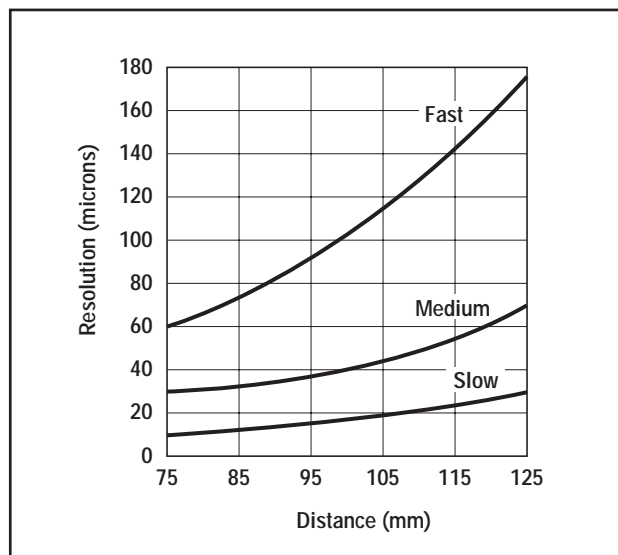
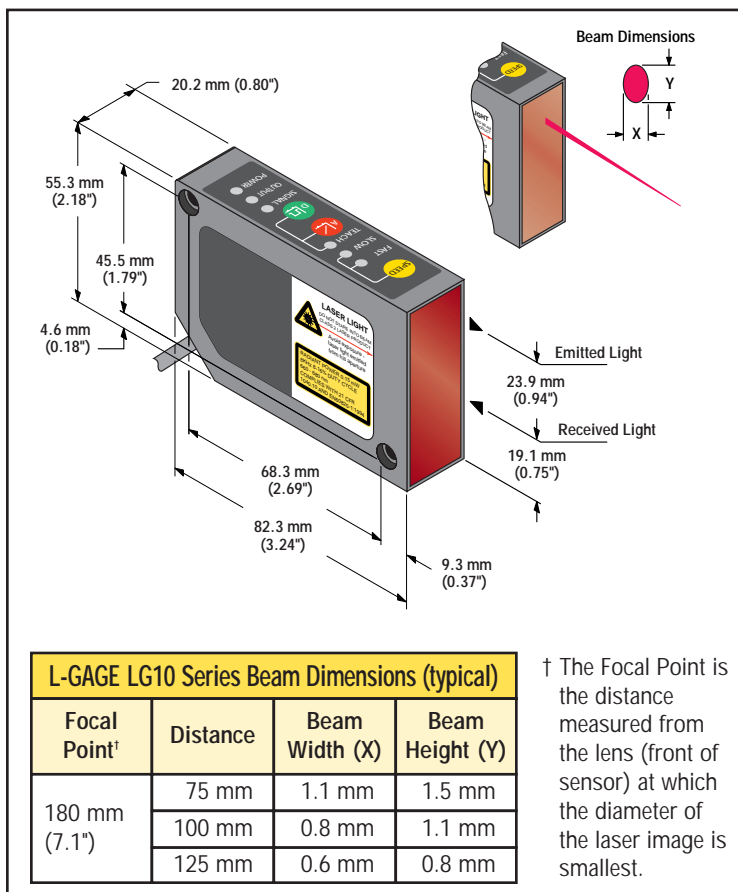

Figure 3. L-GAGE LG10 Series resolution, with respect to speed (typical, using a white ceramic target)

Figure 2. L-GAGE Laser Gauging Sensor and beam dimensions

L-GAGE™ LG10 Series Laser Gauging Sensor

L-GAGE Laser Gauging Sensor Hookups

NPN Hookup

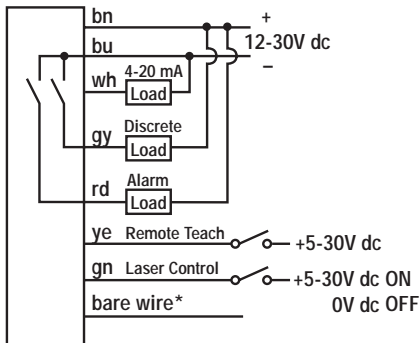

PNP Hookup

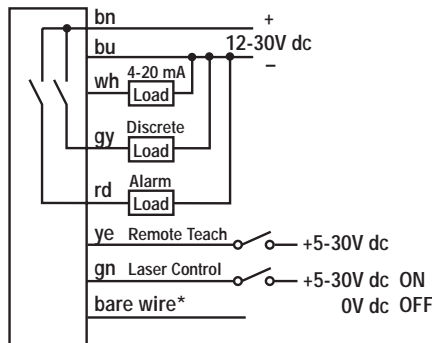

Conversion from Current to Voltage Output

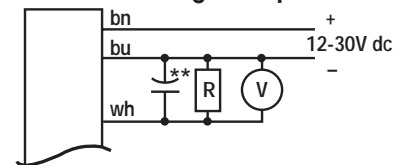

**NOTE:

For best results, install a small amount of capacitance (e.g., 0.1μF) in parallel with the load resistor

*NOTE: The bare shield wire is connected internally to the sensor housing and should be connected as follows:

- 1) If the sensor housing is mounted so that it is in continuity with both the machine frame and earth ground, connect the bare wire (also) to earth ground.
- 2) If the sensor housing is mounted so that it is insulated from the machine frame, connect the bare wire to -V dc (together with the blue wire).
- 3) If the sensor is mounted so that it is in continuity with the machine frame, but not with earth ground, do not connect the bare wire (i.e. cut off the bare wire).

Typical Voltage Response	
Value of R	Output Voltage
250Ω	1 to 5V
500Ω	2 to 10V

Using the L-GAGE Laser Gauging Sensor

Modes

The L-GAGE Laser Gauging Sensor operates in two modes: TEACH (or programming) and RUN.

TEACH-Mode Programming

Response Speed

Use the Speed push button to toggle between the three response speed settings. The combination of indicator lights (Fast and Slow) will tell you which of the three is selected:

Slow	Fast	Analog Output Frequency Response (-3dB)	Discrete Output Response Speed
ON	OFF	10 Hz	40 milliseconds
ON	ON	40 Hz	10 milliseconds
OFF	ON	250 Hz	3.6 milliseconds

L-GAGE™ LG10 Series Laser Gauging Sensor

Window Limits

Window limits may be taught to the sensor in several ways. The following methods describe the TEACH procedures for programming using the sensor push buttons; remote programming (remote TEACH) procedures are described on page 7.

Teaching Limits for Either Analog or Discrete Output

1. Choose the output for the first set of window limits (analog or discrete) and push and hold the corresponding button until the tri-color TEACH LED turns ON (solid). This indicates the sensor is waiting for the first limit: red for analog output, or green for discrete output.
2. Position the target for the first limit and briefly “click” the same button. This will teach the sensor the first limit. The TEACH LED will flash at 2Hz to acknowledge receiving the first window limit; it is now waiting for the second limit.
3. Position the target for the second limit and “click” the button again. This will teach the sensor the second limit. The TEACH LED will turn OFF to indicate that the sensor will now function in normal RUN mode.
4. Repeat for the other output (analog or discrete) if a second output is desired.

Teaching Analog Limits Using the Auto-Zero Feature (Analog Output)

For some analog applications, a sensing distance set point centered within a sensing window may be required. The TEACH procedure is simple: teaching the same limit twice causes the sensor to program a 10 mm wide window centered on the position taught (position ± 5 mm).

Teaching Fixed-Field Sensing Mode (Discrete Output)

Teaching the same limit twice creates a sensing window with the far limit at the teach distance and the near limit at the minimum operating range of the sensor (approximately 60 mm).

Teaching Limits for Both Analog and Discrete Outputs Simultaneously

To set both discrete and analog outputs at exactly the same limits, set both simultaneously.

1. Push and hold either the Analog or the Discrete programming push button until the tri-color TEACH LED turns ON. “Click” the other button (Analog or Discrete). The TEACH LED turns Yellow. The sensor is waiting for the first limit.
2. Position the target for the first limit and “click” either TEACH button. The TEACH LED will flash at 2Hz, alternating red and green, to acknowledge receiving the first window limit; it is now waiting for the second limit.
3. Position the target for the second limit and “click” either button to teach the sensor the second limit. The TEACH LED will turn OFF to indicate that the sensor will now function in normal RUN mode.

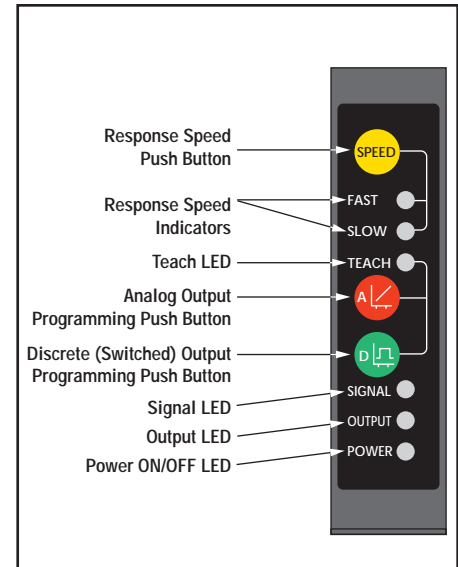

Figure 4. L-GAGE™ Laser Gauging Sensor programming push buttons and indicators

L-GAGE™ LG10 Series Laser Gauging Sensor

Remote Programming

To program the sensor remotely or to disable the keypad, the Remote Programming function may be used. Disabling the keypad prevents anyone on the production floor from adjusting any of the programming settings. Connect the yellow wire of the L-GAGE Laser Gauging Sensor to +5 to 30V dc, with a remote programming switch connected between them. NOTE: The impedance of the remote teach input is 18 k Ω minimum (65 k Ω minimum at 5V).

Programming is accomplished by following the sequence of input pulses, following the button-pushes and “clicks” for programming on the sensor buttons. The duration of each pulse (corresponding to a push button “click”), and the period between multiple pulses, are defined as: 0.04 seconds < T < 0.8 seconds.

To access each of the programming modes, pulse the remote switch a prescribed number of times:

- 1 pulse: Discrete TEACH Mode
- 2 pulses: Analog TEACH Mode
- 3 pulses: Dual Discrete/Analog TEACH Mode
- 4 pulses: Disables (locks out) or enables the keypad for security

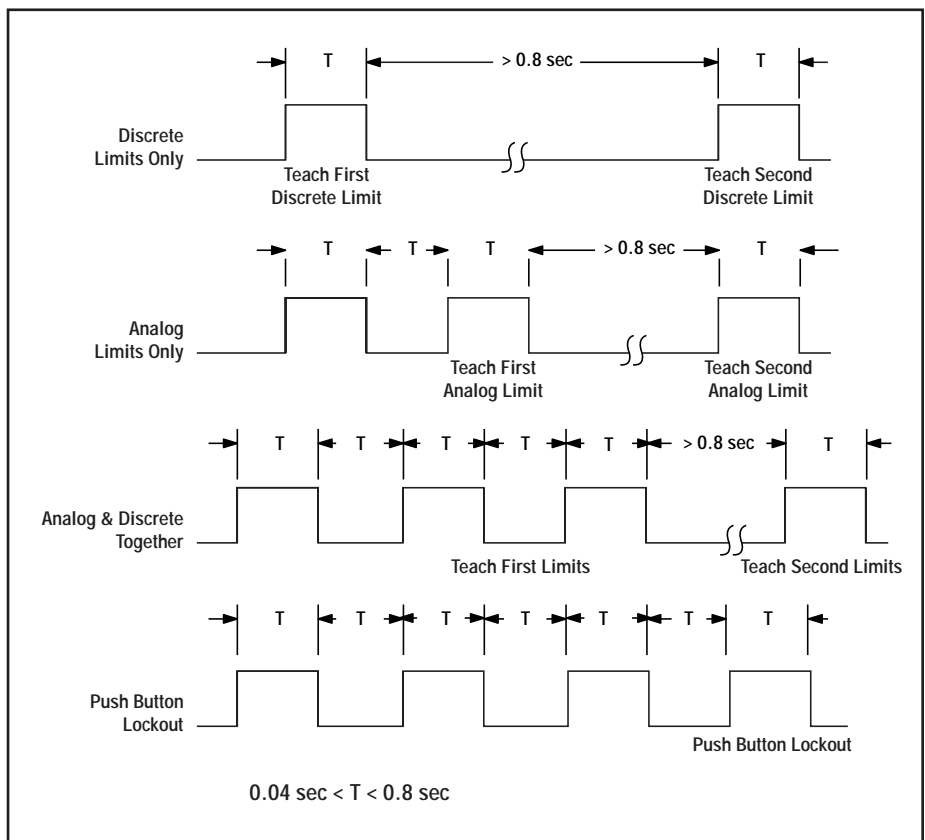

Figure 5. Timing programs for remote TEACH programming

L-GAGE™ LG10 Series Laser Gauging Sensor

RUN Mode

Signal LED

The Signal LED indicates the strength and condition of the sensor's incoming signal.

Signal LED Status	Indicates
OFF	No signal is received, or the target is beyond the range limitations of the sensor (with some tolerance beyond the recommended minimum and maximum sensing distance)
Flashing @ 2Hz	Received signal is adequate for processing
Flashing @ 10Hz	Received signal is in saturation (i.e., signal is too strong); alarm output energizes
ON Solid	Received signal is within the nominal conditions for the sensor

Output LED

The Output LED lights when the discrete output is conducting.

Power ON/OFF LED

The Power ON/OFF LED indicates the operating status of the sensor.

Power ON/OFF LED	Indicates
OFF	Power is OFF
Flashing @ 2Hz	Discrete or alarm output is overloaded
Flashing @ 1Hz	Power ON, Laser is disabled
ON Solid	Sensor is operating normally (power is ON, Laser enabled)

Power Up/Laser Enable

When powering up the sensor, the following should occur:

- All LEDs turn ON for 1 second
- Allow 1.25 second delay for Laser Enable at power up. (If sensor is already powered up, allow 0.25 second for Laser Enable.)

Analog Output

The L-GAGE Laser Gauge may be programmed for either a positive or a negative output slope, based on which condition is taught first (see Figure 6). If the near limit is taught first, the slope will be positive; if the far limit is taught first, the slope will be negative. Banner's unique scalable analog output (patent pending) automatically distributes the output signal over the width of the programmed sensing window. Factory analog output is 4 to 20 mA; if a voltage output (e.g. 1 to 5V dc) is required, this can be accomplished by using an alternate hookup (see Hookups, page 5).

The L-GAGE also features a 2-second hold upon loss of the analog signal, which is useful for profiling and similar applications. In the event of analog signal loss for longer than 2 seconds, the analog output goes to 3.6 mA, which may be used to trigger an alarm.

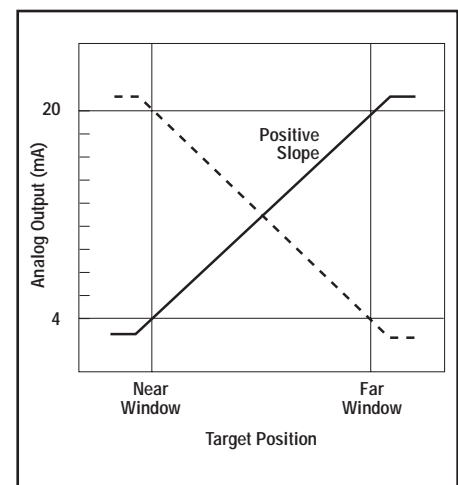

Figure 6. Output current as a function of target position

NOTE: The linear analog output tracks slightly past each window limit (from 3.8 to 20.5 mA).

L-GAGE™ LG10 Series Laser Gauging Sensor

Installation Notes

Some targets (those with a stepped plane facing the sensor, a boundary line, or rounded targets) pose specific problems for sensing distances. For such applications, see figure 7 for suggested mounting orientations.

Class 2 Safety Notes

Low-power lasers are by definition incapable of causing eye injury within the duration of the blink, or aversion response of 0.25 seconds. They must also emit only visible wavelengths (400-700 nm). Therefore, an ocular hazard can only exist if an individual overcomes their natural aversion to bright light and stares directly into the laser beam. The product requirements for these lasers are to have a [hazard] label and to have an indicator light to indicate laser emission.

The two operational safety rules are:

- Do not permit a person to stare at the laser from within the beam
- Do not point the laser at a person's eye at close range

Beam Paths:

The beam emitted by a class 2 laser product should be terminated at the end of its useful path. Open laser beam paths should be located above or below eye level where practical.

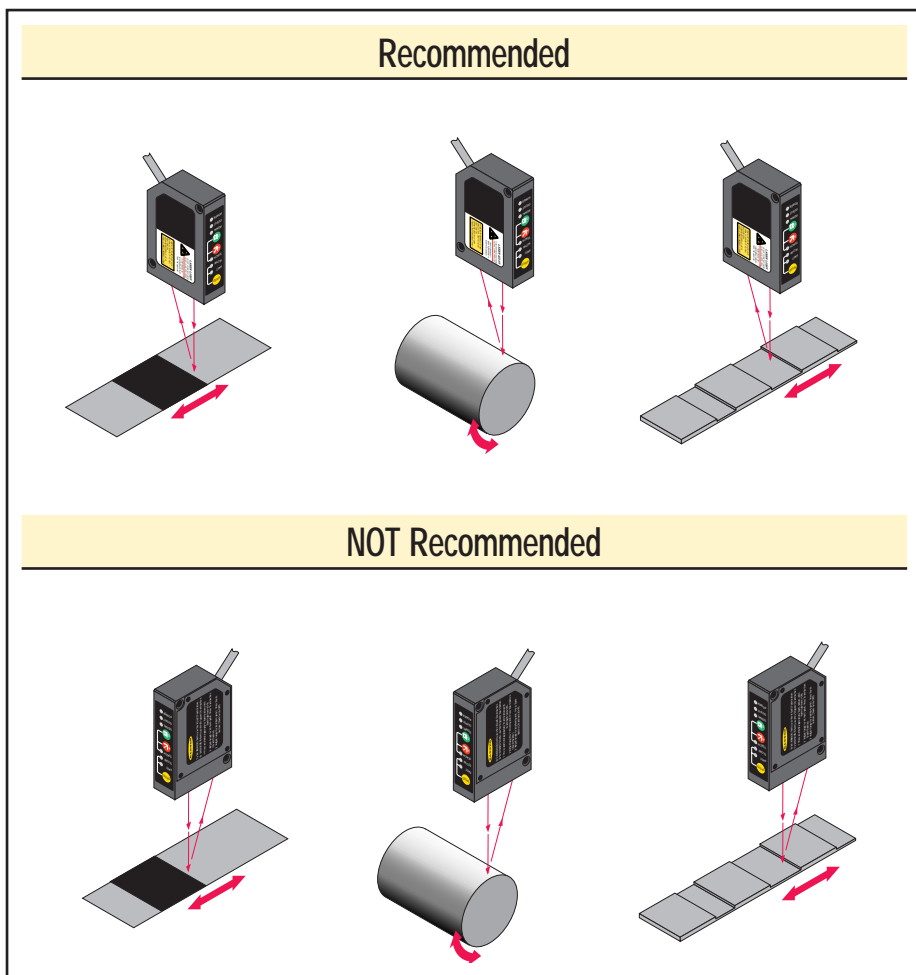
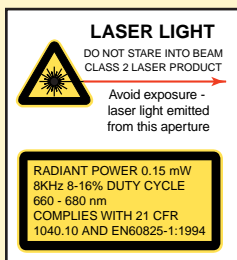



Figure 7. Sensor orientations for typical targets



CAUTION . . .

This sensor contains no user-servicable components. Do not attempt to repair. Incorrect component values may produce hazardous laser radiation levels.

L-GAGE™ LG10 Series Laser Gauging Sensor

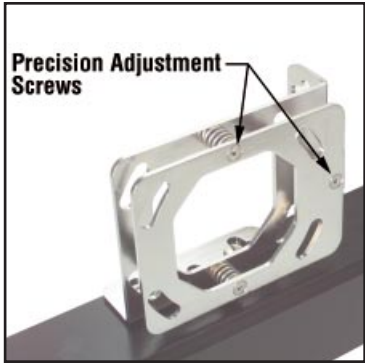
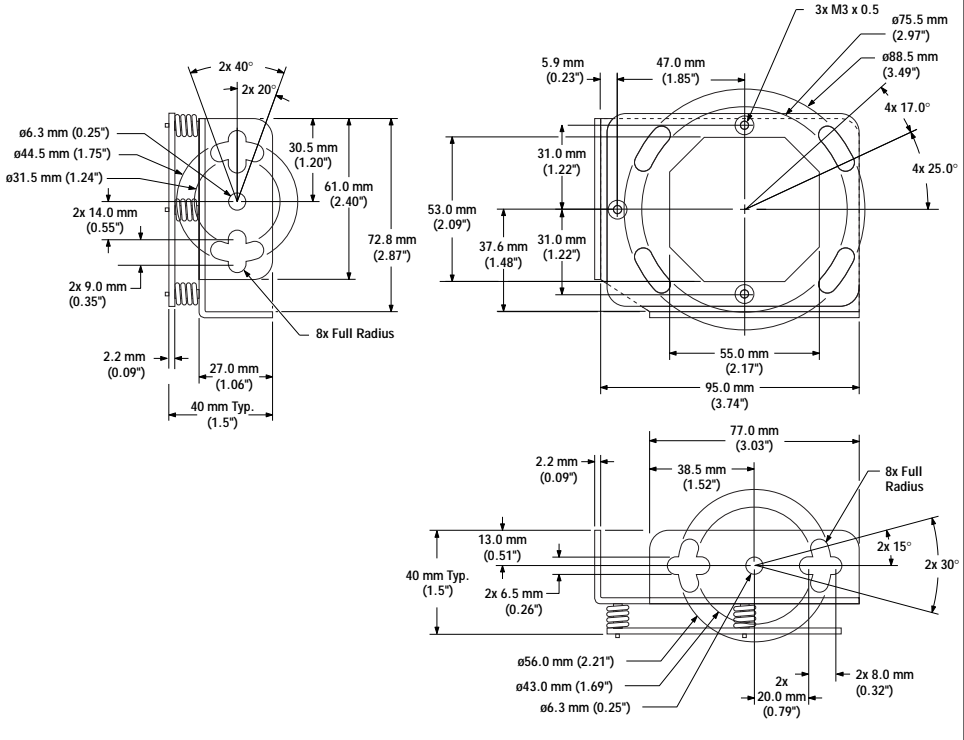
Brackets		
Model	Description	Dimensions
SMBLGA	L-GAGE Adjustable Bracket Assembly • 304 Stainless Steel	   <p>The technical drawing includes the following dimensions:</p> <ul style="list-style-type: none"> Top View Dimensions: <ul style="list-style-type: none"> Overall width: 40 mm Typ. (1.5") Overall height: 72.8 mm (2.87") Inner width: 27.0 mm (1.06") Inner height: 61.0 mm (2.40") Radius: 8x Full Radius Mounting hole diameters: $\phi 6.3$ mm (0.25"), $\phi 44.5$ mm (1.75"), $\phi 31.5$ mm (1.24") Offset dimensions: 2x 14.0 mm (0.55"), 2x 9.0 mm (0.35"), 2.2 mm (0.09") Angles: 2x 40°, 2x 20° Side View Dimensions: <ul style="list-style-type: none"> Overall width: 95.0 mm (3.74") Overall height: 53.0 mm (2.09") Mounting hole diameters: $\phi 75.5$ mm (2.97"), $\phi 88.5$ mm (3.49") Offset dimensions: 5.9 mm (0.23"), 31.0 mm (1.22"), 37.6 mm (1.48") Angles: 4x 17.0°, 4x 25.0° Mounting holes: 3x M3 x 0.5 Bottom View Dimensions: <ul style="list-style-type: none"> Overall width: 77.0 mm (3.03") Overall height: 40 mm Typ. (1.5") Inner width: 38.5 mm (1.52") Inner height: 20.0 mm (0.79") Radius: 8x Full Radius Mounting hole diameters: $\phi 56.0$ mm (2.21"), $\phi 43.0$ mm (1.69"), $\phi 6.3$ mm (0.25") Offset dimensions: 13.0 mm (0.51"), 2x 6.5 mm (0.26"), 2.2 mm (0.09") Angles: 2x 15°, 2x 30°

L-GAGE™ LG10 Series Laser Gauging Sensor



the photoelectric specialist



WARNING . . . Not To Be Used for Personnel Protection

Never use these products as sensing devices for personnel protection. Doing so could lead to serious injury or death.

These sensors do NOT include the self-checking redundant circuitry necessary to allow their use in personnel safety applications. A sensor failure or malfunction can cause either an energized or de-energized sensor output condition. Consult your current Banner Safety Products catalog for safety products which meet OSHA, ANSI and IEC standards for personnel protection.

WARRANTY: Banner Engineering Corporation warrants its products to be free from defects for one year. Banner Engineering Corporation will repair or replace, free of charge, any product of its manufacture found to be defective at the time it is returned to the factory during the warranty period. This warranty does not cover damage or liability for the improper application of Banner products. This warranty is in lieu of any other warranty either expressed or implied.