



## Incremental encoders DFS60, Rotary

DFS60B-TEEK01024



**Model Name** > [DFS60B-TEEK01024](#)  
**Part No.** > [1037382](#)



*Illustration may differ*

**At a glance**

- Compact installation depth
- High resolution up to 16 bits
- Optionally programmable: Output voltage, zero pulse position, zero pulse width and number of pulses
- Connection: Radial or axial cable outlet, M23 or M12 connector, axial or radial
- Electrical interfaces: 5V & 24V TTL/RS-422, 24 V HTL/push pull
- Mechanical interfaces: face mount or servo flange, blind or through hollow shaft
- Remote zero set possible

**Your benefits**

- Reduced storage costs and downtime due to customer-specific programming
- Variety of different mechanical and electrical interfaces enable the encoder to be optimally adjusted to fit the installation situation
- Excellent concentricity even at high speeds
- High resolution of up to 16 bits ensures precise measurements
- Permanent and safe operation due to a high enclosure rating, temperature resistance and a long bearing lifetime
- Programmability via the PGT-08 programming software and the PGT-10-S display programming tool allow the encoder to be adapted flexibly and quickly according to customer needs
- Programmable zero pulse position simplifies installation



**Performance**

|                        |                                       |
|------------------------|---------------------------------------|
| Error limits:          | ± 0.05 °                              |
| Measuring step:        | 90 ° / electronically/number of lines |
| Initialization time:   | 40 ms                                 |
| Pulses per revolution: | 1,024                                 |

**Mechanical data**

|   |                      |
|---|----------------------|
| Mechanical interface:                       | Through hollow shaft |
| Shaft diameter:                             | 12 mm                |
| Mass:                                       | 0.2 kg               |
| Start up torque:                            | 0.8 Ncm (20 °C)      |
| Operating torque:                           | 0.6 Ncm (20 °C)      |
| Permissible movement axial static/dynamic:  | ± 0.5 mm, ± 0.2 mm   |
| Permissible movement radial static/dynamic: | ± 0.3 mm, ± 0.1 mm   |
| Maximum operating speed:                    | 9,000 /min           |

|                                 |                                    |
|---------------------------------|------------------------------------|
| Moment of inertia of the rotor: | 40 gcm <sup>2</sup>                |
| Bearing lifetime:               | 3.6 x 10 <sup>10</sup> revolutions |
| Max. angular acceleration:      | 500,000 rad/s <sup>2</sup>         |
| Shaft material:                 | Metal                              |

#### Electrical data

---

|                             |   |
|-----------------------------|---|
| Electrical interface:       | HTL/Push pull, Cable, 8-pin, universal, 1.5 m |
| Connection type:            | Cable, 8-pin, universal, 1.5 m <sup>1)</sup>  |
| Maximum output frequency:   | 600 kHz                                       |
| Reference signal, number:   | 1   |
| Reference signal, position: | 90 °, electronically, gated with A and B      |
| Operating voltage range:    | 10 V ... 32 V                                 |
| Load current max.:          | 30 mA   |
| Power consumption:          | 0.5 W (without load)                          |

This product is a standard product and does not constitute a safety component as defined in the Machinery Directive.

Calculation based on nominal load of components, average ambient

temperature 40°C, frequency of use 8760 h/a. All

electronic failures are considered hazardous. For more information, see document no. 8015532.;

<sup>1)</sup> The universal cable outlet is positioned in such a way, that it is possible to lay the cable in a radial or axial direction without kinking it

#### Ambient data

---

|                                |  |
|--------------------------------|--|
| EMC:                           | (according to EN 61000-6-2 and EN 61000-6-3)                               |
| Working temperature range:     | -30 °C ... 100 °C  |
| Storage temperature range:     | -40 °C ... 100 °C, without package   |
| Resistance to shocks:          | 70 g (according to EN 60068-2-27)  |
| Resistance to vibration:       | 30 g, 10 Hz ... 2,000 Hz (according to EN 60068-2-6)                       |
| Enclosure rating:              | IP 65 (according to IEC 60529), shaft side, IP 67 (according to IEC 60529) |
| Permissible relative humidity: | 90 % (condensation of the optical scanning not permitted)                  |

## Dimensional drawing

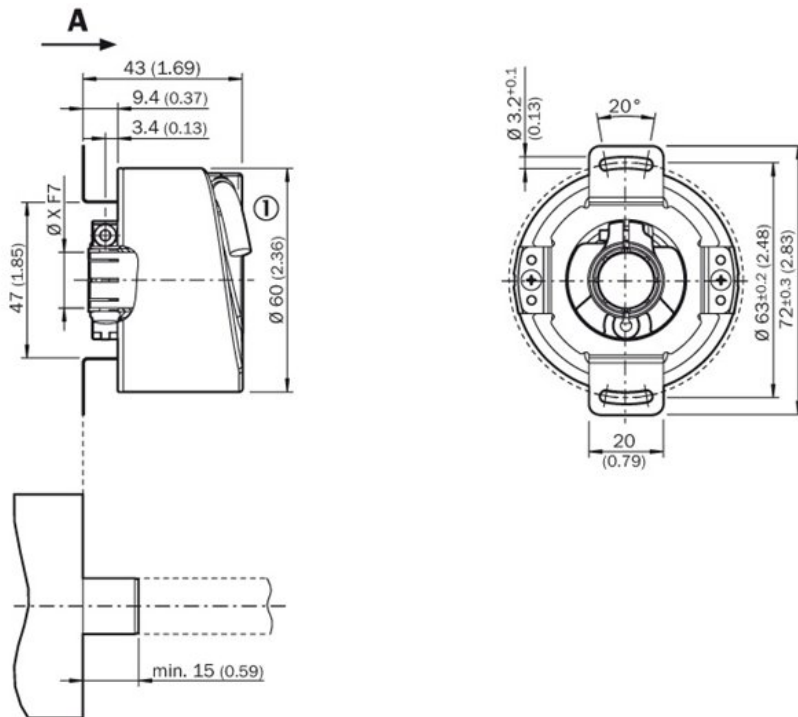

[1] Cable diameter = 5,6 mm  
+/- 2 mm Bending radius = 30 mm

## PIN assignment

### 8-core cable

View of M12 device connector on encoder



View of M23 device connector on encoder



| PIN, 8-pin, M12 connector | PIN, 12-pin, M23 connector | Core colors of encoders with cable outlet | TTL/HTL signal  | Explanation   |
|---------------------------|----------------------------|---|-----------------|---|
| 1                         | 6                          | Brown                                     | A               | Signal cable  |
| 2                         | 5                          | White                                     | A               | Signal cable  |
| 3                         | 1                          | Black                                     | B               | Signal cable  |
| 4                         | 8                          | Pink                                      | B               | Signal cable  |
| 5                         | 4                          | Yellow                                    | Z               | Signal cable  |
| 6                         | 3                          | Lilac                                     | Z               | Signal cable  |
| 7                         | 10                         | Blue                                      | GND             | Ground connection of the encoder  |
| 8                         | 12                         | Red                                       | +U <sub>s</sub> | Supply voltage (volt-free to housing)   |
| -                         | 9                          | -   | N.C.            | Not assigned  |
| -                         | 2                          | -   | N.C.            | Not assigned  |
| -                         | 11                         | -   | N.C.            | Not assigned  |
| -                         | 7 <sup>a</sup>             | -   | SET             | Zero pulse teach  |
| Shield                    | Shield                     | Shield                                    | Shield          | Shield connected to housing on side of encoder. Connected to ground on side of control. |

<sup>a</sup> Only at 4.5 ... 32 V, TTL/HTL programmable

The SET input serves to carry out the zero pulse teach function. If the SET input is applied to U<sub>s</sub> for longer than 250 ms, after it has been open for at least 1,000 ms or applied to GND, the current shaft position is assigned the zero pulse signal "Z".

Image Unavailable

Drehzahlbetrachtung



**Australia**

Phone +61 3 9457 0600  
1800 334 802 – tollfree  
E-Mail sales@sick.com.au

**Belgium/Luxembourg**

Phone +32 (0)2 466 55 66  
E-Mail info@sick.be

**Brasil**

Phone +55 11 3215-4900  
E-Mail sac@sick.com.br

**Canada**

Phone +1 905 771 14 44  
E-Mail information@sick.com

**Ceská Republika**

Phone +420 2 57 91 18 50  
E-Mail sick@sick.cz

**China**

Phone +86 4000 121 000  
E-Mail info.china@sick.net.cn  
Phone +852-2153 6300  
E-Mail ghk@sick.com.hk

**Danmark**

Phone +45 45 82 64 00  
E-Mail sick@sick.dk

**Deutschland**

Phone +49 211 5301-301  
E-Mail kundenservice@sick.de

**España**

Phone +34 93 480 31 00  
E-Mail info@sick.es

**France**

Phone +33 1 64 62 35 00  
E-Mail info@sick.fr

**Great Britain**

Phone +44 (0)1727 831121  
E-Mail info@sick.co.uk

**India**

Phone +91-22-4033 8333  
E-Mail info@sick-india.com

**Israel**

Phone +972-4-6801000  
E-Mail info@sick-sensors.com

**Italia**

Phone +39 02 27 43 41  
E-Mail info@sick.it

**Japan**

Phone +81 (0)3 3358 1341  
E-Mail support@sick.jp

**Magyarország**

Phone +36 1 371 2680  
E-Mail office@sick.hu

**Nederlands**

Phone +31 (0)30 229 25 44  
E-Mail info@sick.nl

**Norge**

Phone +47 67 81 50 00  
E-Mail austefjord@sick.no

**Österreich**

Phone +43 (0)22 36 62 28 8-0  
E-Mail office@sick.at

**Polska**

Phone +48 22 837 40 50  
E-Mail info@sick.pl

**România**

Phone +40 356 171 120  
E-Mail office@sick.ro

**Russia**

Phone +7-495-775-05-30  
E-Mail info@sick.ru

**Schweiz**

Phone +41 41 619 29 39  
E-Mail contact@sick.ch

**Singapore**

Phone +65 6744 3732  
E-Mail admin@sicksgp.com.sg

**Slovenija**

Phone +386 (0)1-47 69 990  
E-Mail office@sick.si

**South Africa**

Phone +27 11 472 3733  
E-Mail info@sickautomation.co.za

**South Korea**

Phone +82 2 786 6321/4  
E-Mail info@sickkorea.net

**Suomi**

Phone +358-9-25 15 800  
E-Mail sick@sick.fi

**Sverige**

Phone +46 10 110 10 00  
E-Mail info@sick.se

**Taiwan**

Phone +886-2-2375-6288  
E-Mail sales@sick.com.tw

**Türkiye**

Phone +90 (216) 528 50 00  
E-Mail info@sick.com.tr

**United Arab Emirates**

Phone +971 (0) 4 8865 878  
E-Mail info@sick.ae

**USA/México**

Phone +1(952) 941-6780  
1 800-325-7425 – tollfree  
E-Mail info@sickusa.com

More representatives and agencies  
at [www.sick.com](http://www.sick.com)