



Photoelectric sensors  
W4S-3, Photoelectric proximity sensor,  
Background suppression

WTB4S-3P3432S05



**Model Name** > [WTB4S-3P3432S05](#)  
**Part No.** > [1051765](#)



*Illustration may differ*

**At a glance**

- Best background suppression in its class
- Setting either via teach-in pushbutton, 5-turn potentiometer cable or by IO-Link
- All models with PinPoint LED technology
- Versions with laser-like LED light spots
- High immunity to ambient light

**Your benefits**

- Less downtime due to reliable detection of all types of objects
- Laser-like light spot provides quick and easy alignment
- Smart machine design makes it possible to mount the sensor in the tightest spaces
- Reliable object detection due to best-in-class background suppression and high immunity to ambient light



**Features**

Sensor/detection principle:	Photoelectric proximity sensor, Background suppression
Dimensions (W x H x D):	12.2 mm x 41.8 mm x 17.3 mm
Housing design (light emission):	Rectangular
Sensing range max.:	3 mm ... 280 mm <sup>1)</sup>
Sensing range:	3 mm ... 280 mm <sup>2)</sup>
Type of light:	Visible red light
Light source:	PinPoint LED <sup>3)</sup>
Wave length:	650 nm
Teach-in:	Single teach-in button
Adjustment:	Teach-in
Light spot size (distance):	Ø 2 mm (100 mm)

<sup>1) 2)</sup> Object with 90 % reflectance (referred to standard white DIN 5033) <sup>3)</sup> Average service life of 100,000 h at T<sub>A</sub> = +25 °C

**Mechanics/electronics**

Supply voltage:	10 V DC ... 30 V DC <sup>1)</sup>
Ripple:	< 5 Vpp <sup>2)</sup>
Power consumption:	≤ 20 mA <sup>3)</sup>
Output type:	PNP
Output function:	Complementary
Switching mode:	Light/dark-switching

Output current I <sub>max</sub> ..:	≤ 100 mA
Response time:	< 0.5 ms <sup>4)</sup>
Switching frequency:	1,000 Hz <sup>5)</sup>
Connection type:	Cable with connector M12, 4-pin, 150 mm <sup>6)</sup>
Cable material:	PVC
Conductor cross-section:	0.14 mm <sup>2</sup>
Cable diameter:	Ø 3.4 mm
Circuit protection:::	A, C, D <sup>7)</sup> 8) 9)
Protection class:	III
Special device:	✓
Housing material:	ABS, Plastic
Optics material:	PMMA
Enclosure rating:	IP 67
Special features:	Small light spot diameter of 2 mm in 100 mm distance
Ambient operating temperature:	-40 °C ... 60 °C
Ambient storage temperature:	-40 °C ... 75 °C
UL File No.:	NRKH.E181493 & NRKH7.E181493

1) Limit values 2) May not exceed or fall short of V<sub>S</sub> tolerances 3) Without load 4) Signal transit time with resistive load 5) With light/dark ratio 1:1 6) Do not bend below 0 °C 7) A = V<sub>S</sub> connections reverse-polarity protected 8) C = interference suppression 9) D = outputs overcurrent and short-circuit protected

## Dimensional drawing

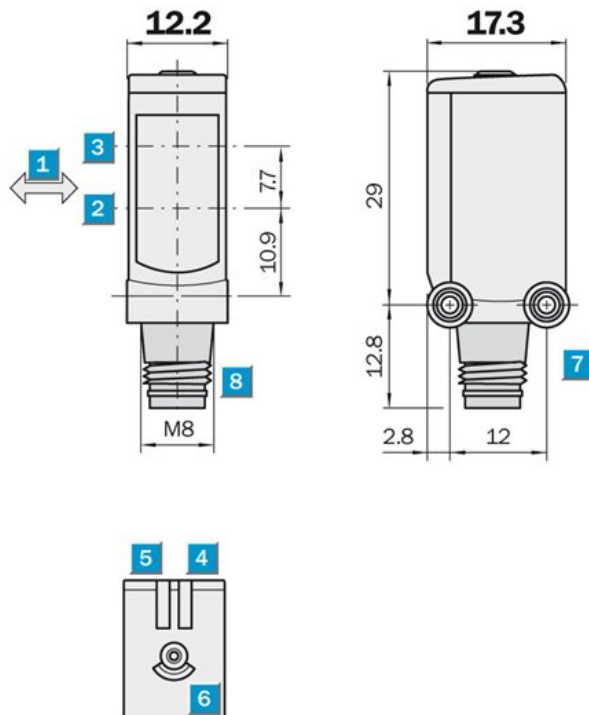

- [1] Standard direction of the material being scanned
- [2] Optical axis receiver
- [3] Optical axis sender
- [4] Status indicator LED green: power on
- [5] Status indicator LED, yellow: Status of received light beam
- [6] Teach-in button
- [7] Threaded mounting hole M3
- [8] Connection

### Connection diagram

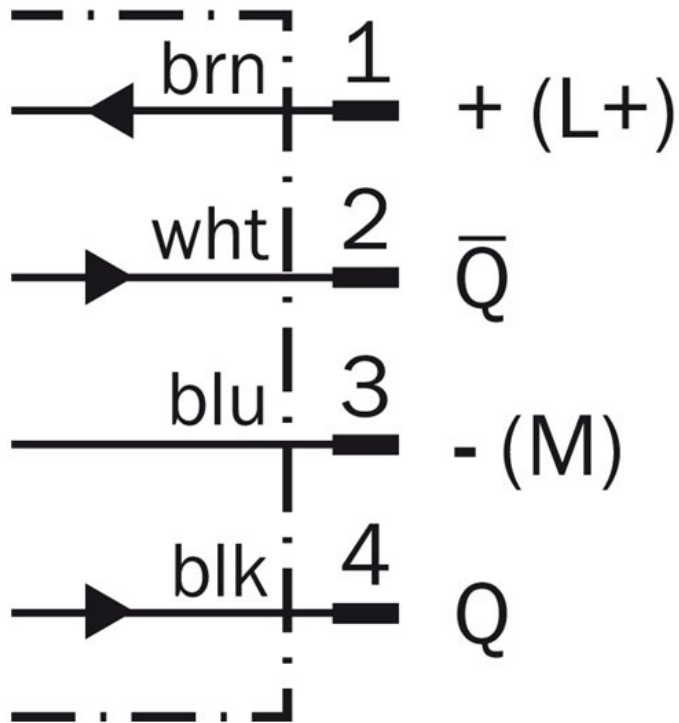

### Characteristic curve

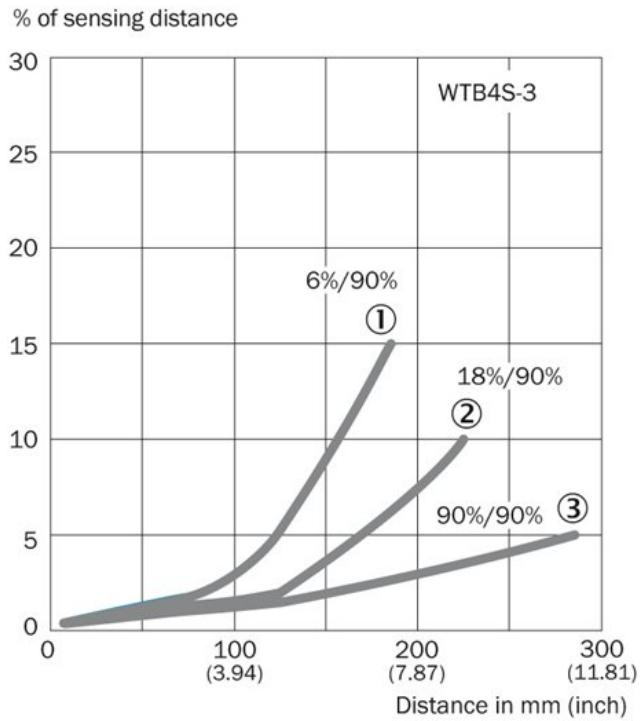

## Connection type



## Sensing range diagram

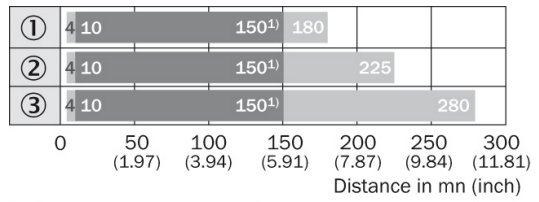

■ Operating distance    ■ Sensing distance typ. max.

- ① Sensing distance on black, 6 % remission
- ② Sensing distance on grey, 18 % remission
- ③ Sensing distance on whitw, 90 % remission

<sup>1)</sup>Due to the focus of the light spot at 100 mm (3.94 inch)

**Australia**

Phone +61 3 9457 0600  
1800 334 802 – tollfree  
E-Mail sales@sick.com.au

**Belgium/Luxembourg**

Phone +32 (0)2 466 55 66  
E-Mail info@sick.be

**Brasil**

Phone +55 11 3215-4900  
E-Mail sac@sick.com.br

**Canada**

Phone +1 905 771 14 44  
E-Mail information@sick.com

**Ceská Republika**

Phone +420 2 57 91 18 50  
E-Mail sick@sick.cz

**China**

Phone +86 4000 121 000  
E-Mail info.china@sick.net.cn  
Phone +852-2153 6300  
E-Mail ghk@sick.com.hk

**Danmark**

Phone +45 45 82 64 00  
E-Mail sick@sick.dk

**Deutschland**

Phone +49 211 5301-301  
E-Mail kundenservice@sick.de

**España**

Phone +34 93 480 31 00  
E-Mail info@sick.es

**France**

Phone +33 1 64 62 35 00  
E-Mail info@sick.fr

**Great Britain**

Phone +44 (0)1727 831121  
E-Mail info@sick.co.uk

**India**

Phone +91-22-4033 8333  
E-Mail info@sick-india.com

**Israel**

Phone +972-4-6801000  
E-Mail info@sick-sensors.com

**Italia**

Phone +39 02 27 43 41  
E-Mail info@sick.it

**Japan**

Phone +81 (0)3 3358 1341  
E-Mail support@sick.jp

**Magyarország**

Phone +36 1 371 2680  
E-Mail office@sick.hu

**Nederlands**

Phone +31 (0)30 229 25 44  
E-Mail info@sick.nl

**Norge**

Phone +47 67 81 50 00  
E-Mail austefjord@sick.no

**Österreich**

Phone +43 (0)22 36 62 28 8-0  
E-Mail office@sick.at

**Polska**

Phone +48 22 837 40 50  
E-Mail info@sick.pl

**România**

Phone +40 356 171 120  
E-Mail office@sick.ro

**Russia**

Phone +7-495-775-05-30  
E-Mail info@sick.ru

**Schweiz**

Phone +41 41 619 29 39  
E-Mail contact@sick.ch

**Singapore**

Phone +65 6744 3732  
E-Mail admin@sicksgp.com.sg

**Slovenija**

Phone +386 (0)1-47 69 990  
E-Mail office@sick.si

**South Africa**

Phone +27 11 472 3733  
E-Mail info@sickautomation.co.za

**South Korea**

Phone +82 2 786 6321/4  
E-Mail info@sickkorea.net

**Suomi**

Phone +358-9-25 15 800  
E-Mail sick@sick.fi

**Sverige**

Phone +46 10 110 10 00  
E-Mail info@sick.se

**Taiwan**

Phone +886-2-2375-6288  
E-Mail sales@sick.com.tw

**Türkiye**

Phone +90 (216) 528 50 00  
E-Mail info@sick.com.tr

**United Arab Emirates**

Phone +971 (0) 4 8865 878  
E-Mail info@sick.ae

**USA/México**

Phone +1(952) 941-6780  
1 800-325-7425 – tollfree  
E-Mail info@sickusa.com

More representatives and agencies  
at [www.sick.com](http://www.sick.com)