



STR1-SAXM0AC5

STR1

NON-CONTACT SAFETY SWITCHES

SICK
Sensor Intelligence.



Ordering information

Type	Part no.
STR1-SAXM0AC5	1085713

Other models and accessories → www.sick.com/STR1



Detailed technical data

Features

System part	Sensor
Sensor principle	Transponder
Number of safe outputs	2
Auxiliary contact (AUX)	1 (Switching behavior complementary to OSSDs)
Safe switch on distance S_{ao}	14 mm (-10 ... +70 °C) ¹⁾ 10 mm (-30 ... -10 °C) ¹⁾
Safe switch off distance S_{ar}	28 mm ¹⁾
Active sensor surfaces	3
Actuation directions	5
Coding	Universally coded

¹⁾ Values apply for the frontal alignment of the sensor to the "Flat" actuator. A detailed display of the alignment options and values can be found in the operating instructions.

Safety-related parameters

Safety integrity level	SIL3 (IEC 61508) SILCL3 (EN 62061)
Category	Category 4 (EN ISO 13849)
Performance level	PL e (EN ISO 13849)
PFH_D (mean probability of a dangerous failure per hour)	5,21 x 10 ⁻⁹ (EN ISO 13849)
T_M (mission time)	20 years (EN ISO 13849)
Type	Type 4 (EN ISO 14119)
Actuator coding level	Low coding level (EN ISO 14119)
Safe state in the event of a fault	At least one safety-related semiconductor output (OSSD) is in the OFF state.

Functions

Safe series connection	With Flexi Loop (with diagnostics)
-------------------------------	------------------------------------

Interfaces

Connection type	Cable with plug M12, 5-pin
------------------------	----------------------------

Length of cable	0.2 m
Cable material	PVC
Long connecting cable	≤ 200 m
Diagnostics indicator	✓
Status display	✓

Electrical data

Protection class	III (IEC 61140)
Classification according to cULus	Class 2
Supply voltage V_s	24 V DC (19.2 V DC ... 28.8 V DC)
Power consumption	50 mA
Type of output	Self-monitoring semiconductor outputs (OSSDs)
Output current	≤ 100 mA
Response time	40 ms ¹⁾
Enable time	100 ms ^{1) 2)}
Risk time	80 ms ^{1) 3)}
Switch-on time	2.5 s ⁴⁾

¹⁾ In a safe series connection, each downstream safety switch increases the system response time. More response times can be found in the operating instructions.

²⁾ Response time on approach to the enable zone.

³⁾ Detection time for internal oder external faults (e.g., short-circuit or cross-circuit of output signal switching devices). Follow the detailed information in the operating instructions.

⁴⁾ The time specified applies to one sensor after the supply voltage has been applied to the safety switch. In a safe series connection, 0.1-s must be added for each sensor. An additional 0.5-s per taught-in actuator must be added for uniquely coded and permanently coded sensors.

Mechanical data

Dimensions (W x H x D)	40 mm x 18 mm x 26 mm
Weight	50 g
Housing material	VISTAL®

Ambient data

Enclosure rating	IP67 (EN 60529) IP69K (ISO 20653)
Ambient operating temperature	-30 °C ... +70 °C ¹⁾
Storage temperature	-30 °C ... +70 °C
Vibration resistance	10 Hz ... 55 Hz, 1 mm (IEC 60068-2-6)
Shock resistance	30 g, 11 ms (IEC 60068-2-27)
EMC	EN IEC 61326-3-1 EN IEC 60947-5-2 EN IEC 60947-5-3 EN 300330 V2.1.1

¹⁾ Only applies for safety switches whose serial numbers begin with number series 1825**** or higher. For safety switches whose serial numbers deviate from this, an ambient operating temperature of -10 °C ... +70 °C applies.
The serial number is displayed on the safety switch over the data matrix code.

Classifications

ECl@ss 5.0	27272403
ECl@ss 5.1.4	27272403
ECl@ss 6.0	27272403

STR1-SAXMOAC5 | STR1

NON-CONTACT SAFETY SWITCHES

ECl@ss 6.2	27272403
ECl@ss 7.0	27272403
ECl@ss 8.0	27272403
ECl@ss 8.1	27272403
ECl@ss 9.0	27272403
ECl@ss 10.0	27272403
ECl@ss 11.0	27272403
ETIM 5.0	EC001829
ETIM 6.0	EC001829
ETIM 7.0	EC001829
UNSPSC 16.0901	39122205

Dimensional drawing (Dimensions in mm (inch))

Sensor with cable and male connector

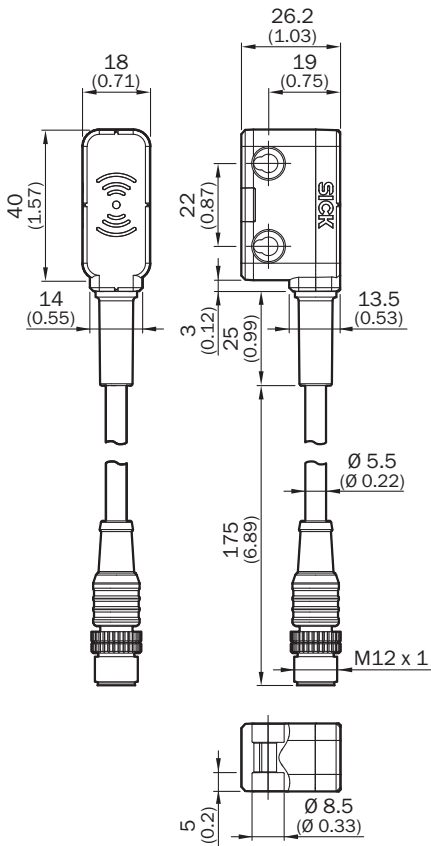

Response range

“Flat”/“Mini” actuator, active side sensor surface

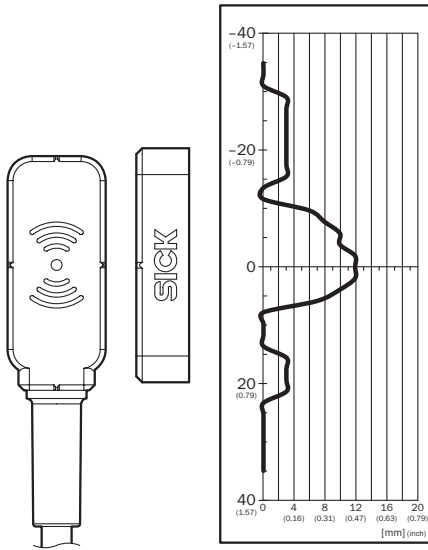

Assured switch on distance Sao 9 mm. Observe border areas for parallel approach: a minimum distance of 4 mm (typical) must be upheld when the actuator moves laterally to the sensor surface. This prevents early triggering due to the side preparation areas.
“Flat”/“Mini” actuator, active front sensor surface

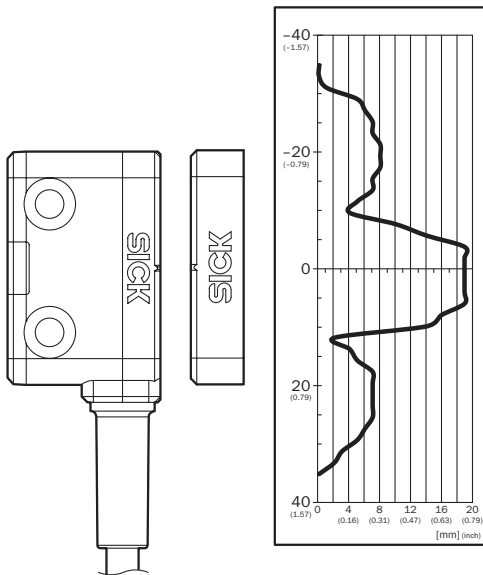

Assured switch on distance Sao 14 mm. Observe border areas for parallel approach: a minimum distance of 10 mm (typical) must be upheld when the actuator moves laterally to the sensor surface. This prevents early triggering due to the side preparation areas.

"Standard" actuator, active front sensor surface

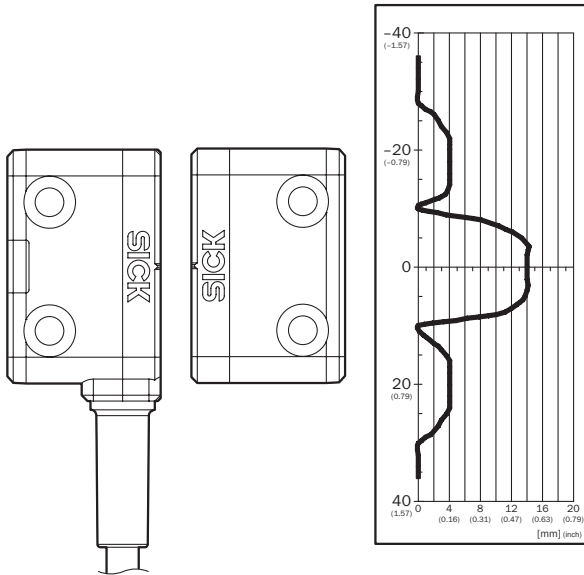

Assured switch on distance S_{a0} 10 mm. Observe border areas for parallel approach: a minimum distance of 6 mm (typical) must be upheld when the actuator moves laterally to the sensor surface. This prevents early triggering due to the side preparation areas. "Standard" actuator, active side sensor surface

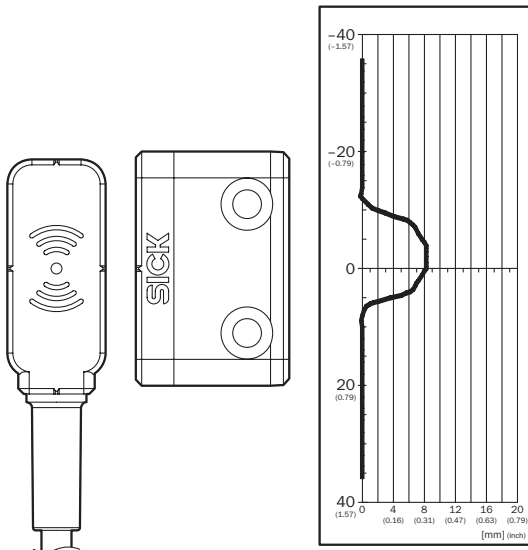

Safe switch on distance S_{a0} 6 mm

Connection diagram

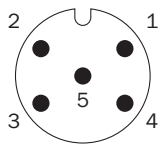

1	Voltage supply 24 V DC
2	OSSD 1
3	Voltage supply 0 V DC
4	OSSD 2
5	Aux output (not safe)

Connection single sensor

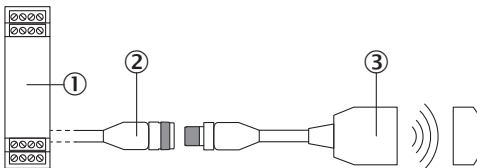

- ① Safe evaluation unit
- ② Connecting cable with 5-pin, M12 female connector and flying leads (e.g., YF2A15-xxxVB5XLEAX)
- ③ STR1 transponder safety switch (e.g., STR1-SAx0AC5)

Series connection

Series connection with Flexi Loop (with diagnostics)

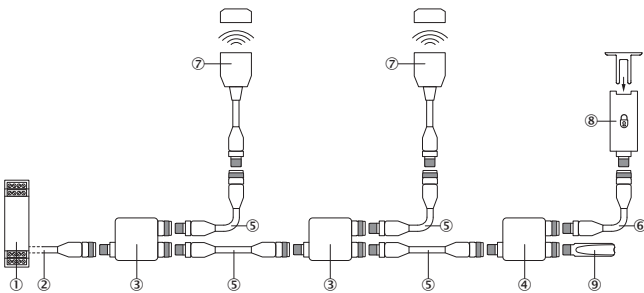

- ① Flexi Soft safety controller
- ② Connecting cable with 5-pin, M12 female connector and flying leads (e.g., YF2A15-xxxVB5XLEAX)
- ③ FLN-OSSD1000105 Flexi Loop node
- ④ FLN-EMSS1100108 Flexi Loop node
- ⑤ Connection cable with 5-pin, M12 male connector and 5-pin, M12 female connector (e.g., YF2A15-xxxUB5M2A15)
- ⑥ Connection cable with 8-pin, M12 male connector and 8-pin, M12 female connector (e.g., YF2A18-xxxUA5M2A18)
- ⑦ STR1 transponder safety switch (e.g., STR1-SAx0AC5)
- ⑧ Safety locking device (e.g., i10-x0454 or i110-x0454)
- ⑨ FLT-TERM00001 Flexi Loop terminating element

STR1 transponder safety switch to RLY3-OSSD2 safety relay

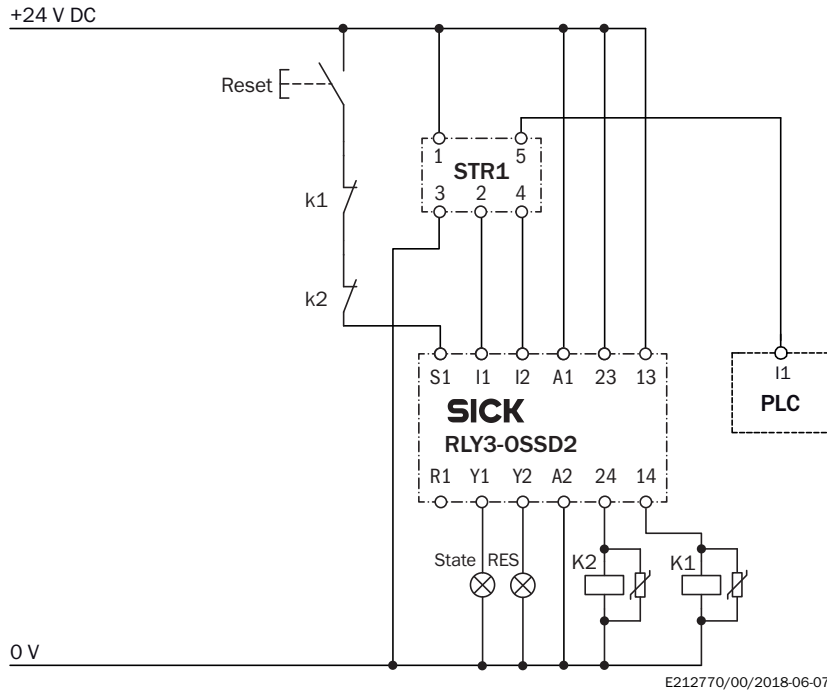

Parallel connection of two STR1 transponder safety switches to a Flexi Classic safety controller

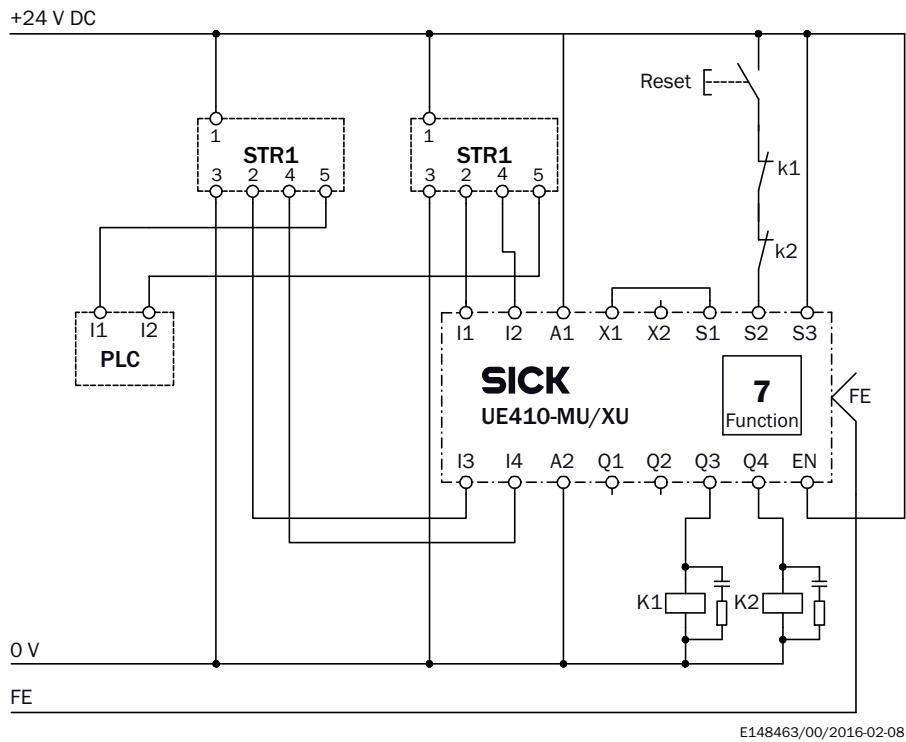

Recommended accessories

Other models and accessories → www.sick.com/STR1

	Brief description	Type	Part no.
Plug connectors and cables			
	Head A: female connector, M12, 5-pin, straight, A-coded Head B: Flying leads Cable: Sensor/actuator cable, PVC, unshielded, 2 m	YF2A15-020VB5XLEAX	2096239
	Head A: female connector, M12, 5-pin, straight, A-coded Head B: Flying leads Cable: Sensor/actuator cable, PVC, unshielded, 5 m	YF2A15-050VB5XLEAX	2096240
	Head A: female connector, M12, 5-pin, straight, A-coded Head B: Flying leads Cable: Sensor/actuator cable, PVC, unshielded, 10 m	YF2A15-100VB5XLEAX	2096241

SICK AT A GLANCE

SICK is one of the leading manufacturers of intelligent sensors and sensor solutions for industrial applications. A unique range of products and services creates the perfect basis for controlling processes securely and efficiently, protecting individuals from accidents and preventing damage to the environment.

We have extensive experience in a wide range of industries and understand their processes and requirements. With intelligent sensors, we can deliver exactly what our customers need. In application centers in Europe, Asia and North America, system solutions are tested and optimized in accordance with customer specifications. All this makes us a reliable supplier and development partner.

Comprehensive services complete our offering: SICK LifeTime Services provide support throughout the machine life cycle and ensure safety and productivity.

For us, that is “Sensor Intelligence.”

WORLDWIDE PRESENCE:

Contacts and other locations –www.sick.com