

RI360P1-DSU35TC-ELI-EXI

Inductive Angle Sensor – With Analog Output

Premium Line

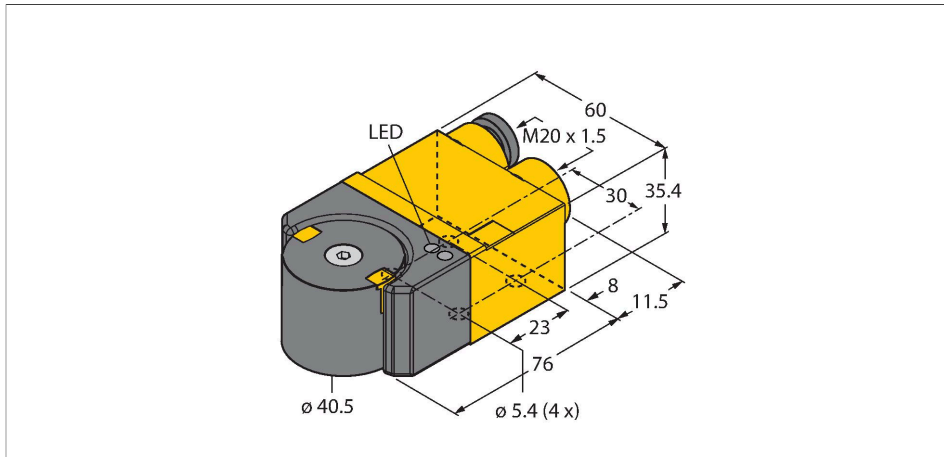

Features

- Rectangular, housing DSU35
- Plastic, PP-GF30-VO
- Detecting angular positions of 0° to 360°
- P1-Ri-DSU35 positioning element included in delivery
- Measuring range programmable via switch in the Terminal chamber
- Immune to electromagnetic interference
- Resolution, 12-bit
- 2-wire, 14...30 VDC
- Analog output
- 4 ... 20 mA
- Terminal chamber
- ATEX category II 2 G, Ex Zone 1
- ATEX category II 2 D, Ex Zone 21

Technical data

Type	RI360P1-DSU35TC-ELI-EXI
Ident. no.	1593015
Measuring principle	Inductive
Resolution	0.09°
Measuring range	0...360 °
Nominal distance	1 mm
Repeat accuracy	≤ 0.025 % of full scale
Linearity deviation	≤ 0.6 %f.s.
Temperature drift	≤ ± 0.02 % / K
Ambient temperature	-25...+70 °C
	For explosion hazardous areas see instruction leaflet
Operating voltage	14...30 VDC
	at the connection point of the sensor
Residual ripple	≤ 10 % U _{ss}
Isolation test voltage	≤ 0.5 kV
Short-circuit protection	yes
Wire breakage/Reverse polarity protection	yes / Complete
Output type	Absolute singleturn
Output function	2-wire, Analog output
Current output	4...20 mA
Diagnostic	Positioning element not within detection range: Output signal 22 mA
	22 mA loop current during teach

Wiring diagram

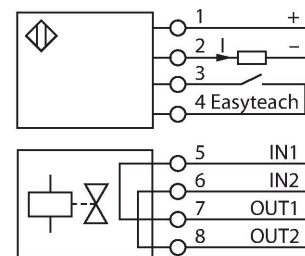

Functional principle

Inductive measuring principle provides more safety
 Based on the functional principle of RLC coupling, the sensor operates absolutely wear-free and is immune to magnetized metal splinters and other interference fields.
 Owing to the differential analysis, the output signal remains almost unchanged, even if the position of the positioning element deviates from the ideal axis of rotation.

Technical data

Load resistance current output	$\leq [(U_b - 14 \text{ V}) / 20 \text{ mA}] \text{ k}\Omega$
Sample rate	500 Hz
Valve control	Exi (max. 30 V)
Approval acc. to	KEMA 03 ATEX 1122 X Issue no. 2
Internal capacitance (C)/inductance (L)	0 nF/0 μ H
Device marking	$\text{\textcircled{Ex}}$ II 2 G Ex ia IIC T6 Gb / II 2 D Ex ia IIIC T85 °C Db (max. $U_i = 30 \text{ V}$, $I_i = 120 \text{ mA}$, $P_i = 600\text{mW}$)
Design	DSU35
Dimensions	71 x 60 x 35.4 mm
Flange type	Flange without mounting element
Housing material	Plastic, PP-GF30
Housing material, positioning element	plastic, PA66 + PA6I/6T-GF40
Electrical connection	Terminal chamber
Vibration resistance	55 Hz (1 mm)
Shock resistance	30 g (11 ms)
Protection class	IP68 / IP69K
MTTF	138 years acc. to SN 29500 (Ed. 99) 40 °C
Included in delivery	Positioning element P1-Ri-DSU35, countersunk screw M6 x 25, 2x cylinder screws M5 x 12, 2x lock washers A5, 2x cable glands (blue), 1x dummy plug

Mounting instructions

Mounting instructions/Description

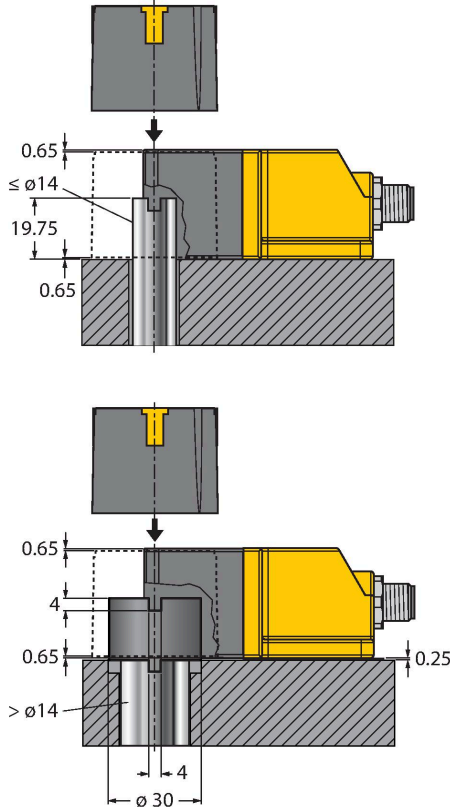

Ri-DSU35 for mounting on rotary actuators
 The Ri-DSU35 angle sensor and the well-established Ni4-DSU35 inductive dual sensor are identical in construction. The user also profits from the enormous mounting flexibility of the device. The sensor can be mounted on all standard rotary actuators with a shaft diameter of max. 14 mm thanks to an extensive range of available accessories. For larger shaft diameters use the BTS-DSU35-Z02 accessories.

Teaching with positioning element

The teach-in process can be carried out simply and reliably using the switch installed in the terminal chamber.

The increased current required during the teach-in process can be provided by an IMX12-DO01-1U-1U-0/24VDC, 7580101, for example.

Teach pulse	LED 1	LED 2
Approx. 3 s – start value	Lights up green, easy teach starts, fast flash on completion	Flashes 1 x, then stop teach pulse => start value set
Approx. 5 s – end value		Flashes 2 x, then stop teach pulse => end value set
Approx. 8 s – change of direction		Flashes 3 x, then stop teach pulse => change of CW/CCW direction
Approx. 12 s – factory setting		Flashes 4 x, then stop teach pulse => factory setting reset (360° measuring range, CW direction)

Accessories

BTS-DSU35-Z01

6900229

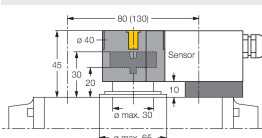

Mounting kit for dual sensors for larger rotary actuators; Ø spacer plate and snap ring: max. 65 mm; hole pattern on receptacle surface: 30 x 80 mm (30 x 130 mm); connection

BTS-DSU35-Z02

6900230

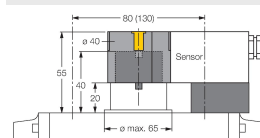

Mounting kit for dual sensors for larger rotary actuators; Ø spacer plate and snap ring: max. 65 mm; hole pattern on receptacle surface: 30 x 80 mm (30 x 130 mm); connection

shaft (shaft extension) height: 20 mm/
 \varnothing : max. 30 mm

shaft (shaft extension) height: 20 mm
 (30 mm)/ \varnothing : max. 40 mm

BTS-DSU35-Z03

6900231

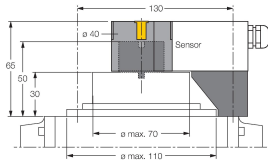

Mounting kit for dual sensors for larger rotary actuators; \varnothing spacer plate and snap ring: max. 110 mm; hole pattern on receptacle surface: 30 x 130 mm; connection shaft (shaft extension) height: 30 mm/ \varnothing : max. 70 mm

BTS-DSU35-Z07

6900403

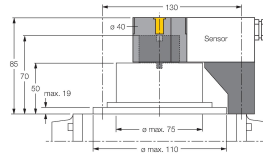

Mounting kit for dual sensors for larger rotary actuators; \varnothing spacer plate and snap ring: max. 110 mm; hole pattern on receptacle surface: 30 x 130 mm; connection shaft (shaft extension) height: 50 mm/ \varnothing : max. 75 mm

P4-RI-DSU35

100002204

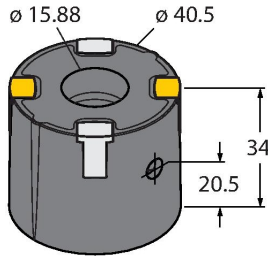

Positioning element for angle sensors RI-DSU35

P1-RI-DSU35

6901086

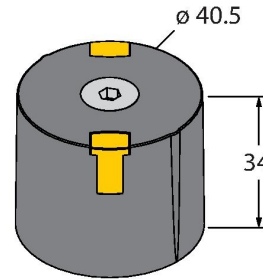

Positioning element for angle sensors RI-DSU35

Operating Instructions

Intended use

This device fulfills the directive 2014/34/EC and is suited for use in explosion hazardous areas according to EN60079-0:2012 + A11 -11:2012. In order to ensure correct operation to the intended purpose it is required to observe the national regulations and directives.

For use in explosion hazardous areas conform to classification

II 2 G and II 2 D (Group II, Category 2 G, electrical equipment for gaseous atmospheres and category 2 D, electrical equipment for dust atmospheres)

Marking (see device or technical data sheet)

⊕ II 2 G Ex ia IIC T6 Gb and ⊕ II 2 D Ex ia IIIC T85 °C Db acc. to EN 60079-0, -11

⊕ II 2 D and Ex ia IIIC T100°C Db acc. to EN61241

Local admissible ambient temperature

-25...+66 °C

Installation/Commissioning

These devices may only be installed, connected and operated by trained and qualified staff. Qualified staff must have knowledge of protection classes, directives and regulations concerning electrical equipment designed for use in explosion hazardous areas. Please verify that the classification and the marking on the device comply with the actual application conditions.

This device is only suited for connection to approved Exi circuits according to EN 60079-0 and EN 60079-11. Please observe the maximum admissible electrical values. After connection to other circuits the sensor may no longer be used in Exi installations. When interconnected to (associated) electrical equipment, it is required to perform the "Proof of intrinsic safety" (EN60079-14).

Installation and mounting instructions

Avoid static charging of cables and plastic devices. Please only clean the device with a damp cloth. Do not install the device in a dust flow and avoid build-up of dust deposits on the device. If the devices and the cable could be subject to mechanical damage, they must be protected accordingly. They must also be shielded against strong electro-magnetic fields. The pin configuration and the electrical specifications can be taken from the device marking or the technical data sheet. In order to avoid contamination of the device, please remove possible blanking plugs of the cable glands or connectors only shortly before inserting the cable or opening the cable socket.

Special conditions for safe operation

The device must be protected against any kind of mechanical damage, avoid static charging.

Service/Maintenance

Repairs are not possible. The approval expires if the device is repaired or modified by a person other than the manufacturer. The most important data from the approval are listed.