

BI2-Q10S-AZ31X 7M

Inductive Sensor

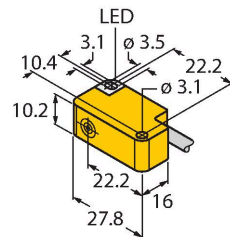

Features

- Rectangular, height 10.2 mm
- Active face, lateral
- Cable outlet to all sides
- Plastic, PP-GF20
- AC 2-wire, 20...250 VDC
- DC 2-wire, 10...300 VDC
- NO contact
- Cable connection

Wiring diagram

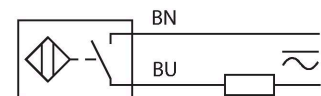

Functional principle

Inductive sensors detect metal objects contactless and wear-free. For this, they use a high-frequency electromagnetic AC field that interacts with the target. Inductive sensors generate this field via an RLC circuit with a ferrite coil.

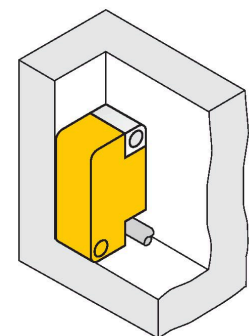

Technical data

Type	BI2-Q10S-AZ31X 7M
Ident. no.	1309102
Rated switching distance	2 mm
Mounting conditions	Flush
Secured operating distance	$\leq (0.81 \times S_n)$ mm
Correction factors	St37 = 1; Al = 0.3; stainless steel = 0.7; Ms = 0.4
Repeat accuracy	≤ 2 % of full scale
Temperature drift	$\leq \pm 10$ %
Hysteresis	3...15 %
Ambient temperature	-25...+70 °C
Operating voltage	20...250 VAC
Operating voltage	10...300 VDC
AC rated operational current	≤ 100 mA
DC rated operational current	≤ 100 mA
Frequency	$\geq 50 \dots \leq 60$ Hz
Residual current	≤ 1.7 mA
Isolation test voltage	≤ 1.5 kV
Surge current	≤ 1 A (≤ 10 ms max. 5 Hz)
Voltage drop at I_o	≤ 6 V
Output function	2-wire, NO contact
Smallest operating current	≥ 3 mA
Switching frequency	0.02 kHz

Technical data

Design	Rectangular, Q10S
Dimensions	27.8 x 16 x 10.2 mm
Housing material	Plastic, PP-GF20
Active area material	PP-GF20
Electrical connection	Cable
Cable quality	Ø 3 mm, Gray, Lif9Y-11Y, PUR, 7 m
Core cross-section	2 x 0.14 mm ²
Vibration resistance	55 Hz (1 mm)
Shock resistance	30 g (11 ms)
Protection class	IP67
MTTF	2283 years acc. to SN 29500 (Ed. 99) 40 °C
Switching state	LED, Yellow

Mounting instructions

Mounting instructions/Description

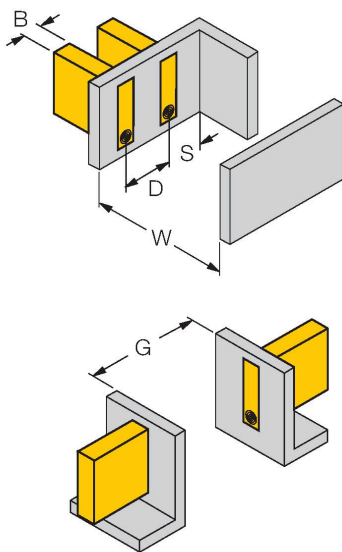

Distance D	2 x B
Distance W	3 x Sn
Distance S	1 x B
Distance G	6 x Sn
Width active area B	10.2 mm