

# NI25-CQ40/S1102 10M

## Inductive Sensor – With Increased Temperature Range

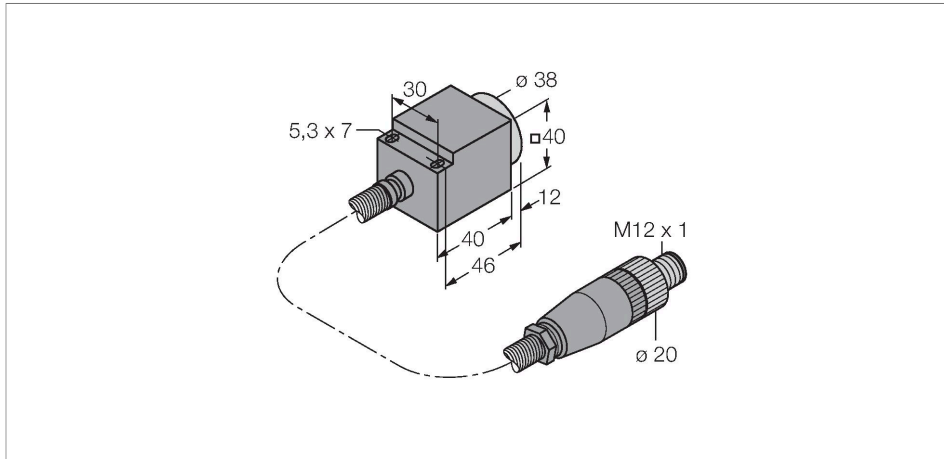

### Features

- Rectangular, height 40 mm
- Sensor housing, Aluminium
- Plastic, PEEK
- Aluminium cable sheath
- For temperatures up to +250 °C
- Functions only with signal processor EM30-AP6X2-H1141/S1102
- Switchpoint adjusted at the processing unit
- 3-wire connection to the processor

### Wiring diagram

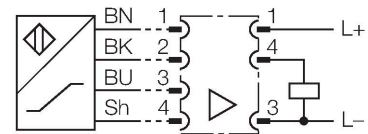

### Technical data

Type	NI25-CQ40/S1102 10M
Ident. no.	1602403
Special version	S1102 corresponds to: Ambient temperature up to 250 °C
Rated switching distance	25 mm
Mounting conditions	Non-flush, partially embeddable
Secured operating distance	$\leq (0.81 \times S_n)$ mm
Correction factors	St37 = 1; Al = 0.3; stainless steel = 0.7; Ms = 0.4
Repeat accuracy	$\leq 2$ % of full scale
Hysteresis	3...15 %
Ambient temperature	0...+250 °C
Output function	NO contact, PNP
Design	Rectangular, CQ40
Dimensions	52 x 40 x 40 mm
Housing material	Plastic, AL
Active area material	PEEK
Electrical connection	Connector, M12 x 1 max. connector temperature -20...+70°C
Cable quality	$\varnothing$ 3.7 mm, PTFE, FEP, 10 m Al cable sheath, $\varnothing$ 8 mm
Core cross-section	3 x 0.34 mm <sup>2</sup>
Vibration resistance	55 Hz (1 mm)
Shock resistance	30 g (11 ms)
Protection class	IP60

### Functional principle

The sensors must be operated with an EM30-AP6X2-H1141/S1102 signal processor. The switching distance is set using a potentiometer (continuous) on the signal processor. This is located under a cover screw next to the LED. Where possible, the switching distance must be set at operating temperature. When setting the switching distance at room temperature, the temperature sensitivity of the sensor system must be taken into account.

Setting:

1. Place the target (steel, min. 1 mm thick, square, edge length min. 3x rated switching distance) at a safe switching distance in front of the sensor
2. Turn the potentiometer counterclockwise until the LED lights up green
3. Turn the potentiometer clockwise until the LED lights up yellow
4. Perform functional checks in the operating state

## Technical data

MTTF

1685 years acc. to SN 29500 (Ed. 99) 40 °C

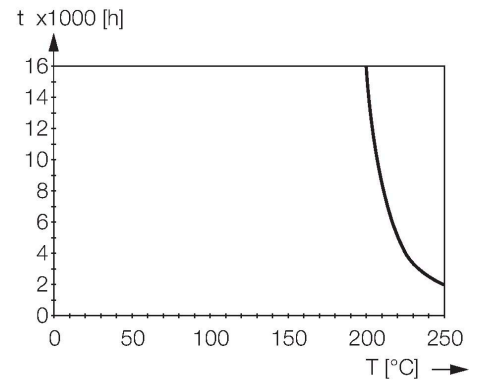

## Mounting instructions

### Mounting instructions/Description

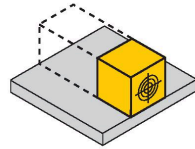
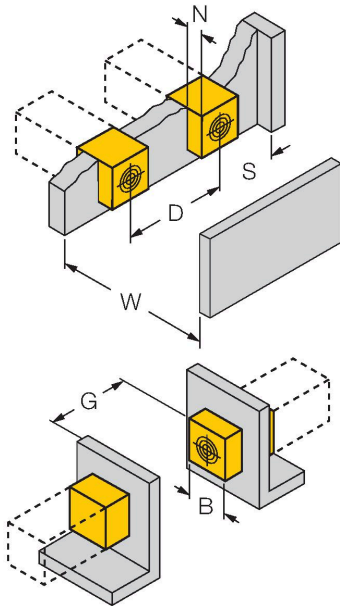

Distance D	2 x B
Distance W	3 x Sn
Distance S	1.5 x B
Distance G	6 x Sn
Distance N	2 x Sn
Distance A	1 x Sn
Width active area B	40 mm

1-side mounting on metal without modification of the switching distance

## Accessories

EM30-AP6X2-H1141/S1102

1602411

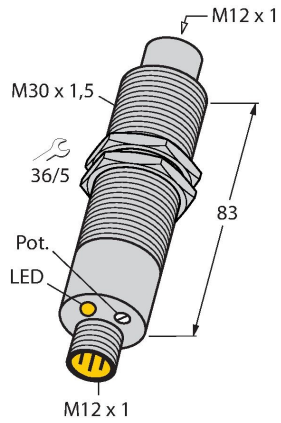

Signal processor for 250 °C sensor;  
housing material: Stainless steel  
1.4571; protection type: IP67; function  
display: LED/yellow; power ON  
indication: LED/green; ambient  
temperature: -25 °C...+70 °C