

NI2-Q9.5-AP6-0.1-FS4.4X3/S304

Inductive Sensor – Monitoring Kit for Power Clamps

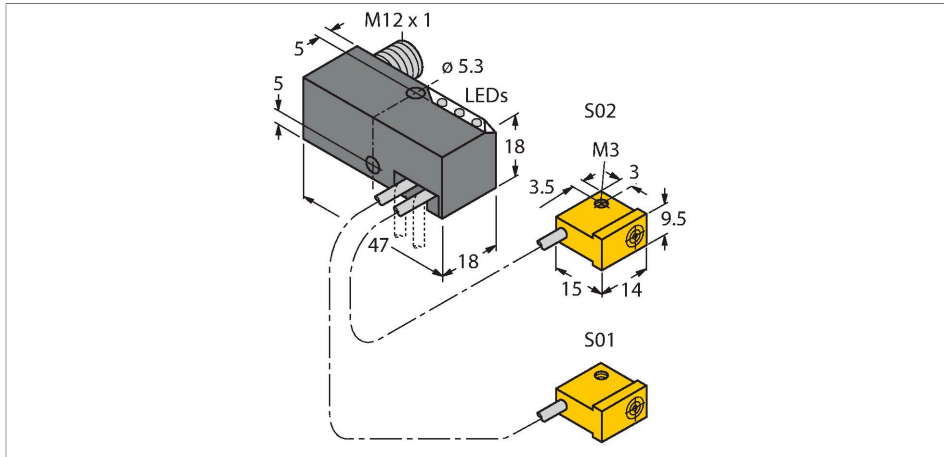

Technical data

Type	NI2-Q9.5-AP6-0.1-FS4.4X3/S304
Ident. no.	1650060
Special version	S304 corresponds to: 2 × Ni../Bi../-AP(N)6/S34. Function for DeviceNet. Defined length at connector FS4.4/FS4.4K or FSF5.5/FSF5.5K (with PE connection) or FS4.4X3. Example for order : Ni2-Q6.5-AP6-0.1-FSF4.4X3/S304
Rated switching distance	2 mm
Mounting conditions	Non-flush
Secured operating distance	$\leq (0.81 \times S_n)$ mm
Correction factors	St37 = 1; Al = 0.3; stainless steel = 0.7; Ms = 0.4
Repeat accuracy	≤ 2 % of full scale
Temperature drift	$\leq \pm 10$ %
Hysteresis	3...15 %
Ambient temperature	-25...+70 °C
Operating voltage	10...30 VDC
Residual ripple	≤ 10 % U_{ss}
DC rated operational current	≤ 150 mA
No-load current	≤ 20 mA
Residual current	≤ 0.1 mA
Isolation test voltage	≤ 0.5 kV
Short-circuit protection	yes / Cyclic
Voltage drop at I_o	≤ 1.8 V
Wire breakage/Reverse polarity protection	Complete

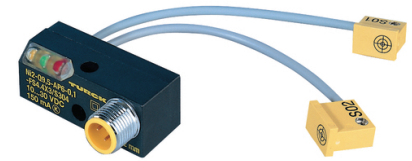

Features

- Q9,5 power block with two connected sensors and LEDs
- Relocatable block 0°...90°, with cross drilling for flexible cable routing
- Plastic, PP GR-20
- Resistant to magnetic fields (weld-resistant), for DC and AC fields up to 100 mT
- 2 x NO contact, PNP output
- DC 4-wire, 10...30 VDC

Wiring diagram

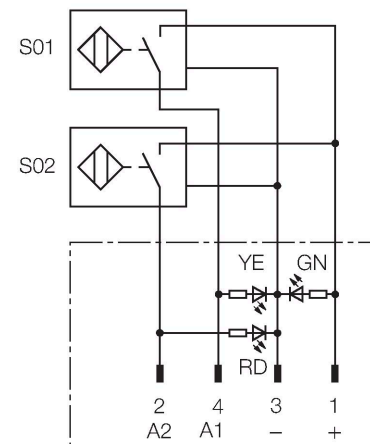

Functional principle

TURCK offers special monitoring kits, consisting of two miniature sensors, as a convenient solution for "Open/Closed" detection on pneumatic power clamps. This product line provides almost unlimited combination possibilities, comprising four different power blocks and over 40 different modular sensor types.

Technical data

Output function	4-wire, NO contact, PNP
Smallest operating current	≥ 1 mA
Switching frequency	0.03 kHz
Design	Monitoring kit for power clamps, Q9,5
Dimensions	47 x 18 x 18 mm
Housing material	Metal, PBT-GF20-V0
Active area material	Plastic, PP GR-20
Electrical connection	Connector, M12 x 1
Cable quality	\varnothing 2 mm, Gray, Lif9Y-11Y, PUR, 0.1 m
Core cross-section	3 x 0.08 mm ²
Litz wire	40 x 0.05 mm
Vibration resistance	55 Hz (1 mm)
Shock resistance	30 g (11 ms)
Protection class	IP67
MTTF	2283 years acc. to SN 29500 (Ed. 99) 40 °C
Power-on indication	LED, Green
Switching state	2 x LEDs, Yellow/Red

Mounting instructions

Mounting instructions/Description

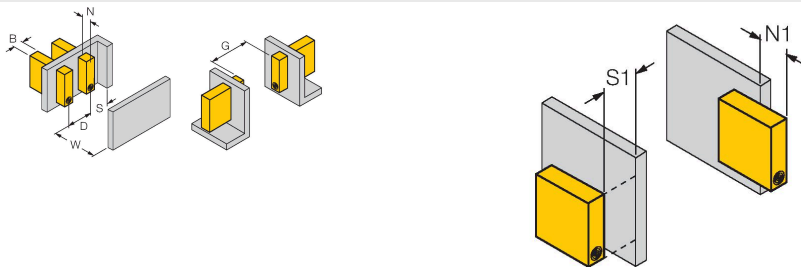

Distance D	3 x B
Distance W	3 x Sn
Distance S	1.5 x B
Distance G	6 x Sn
Distance N	2 x Sn
Width active area B	6.5 mm

Please note, non-flush mounting of this sensor is obligatory.

The following conditions allow semi-flush mounting:

N1 = 0 mm and S1 = 1 mm or

N1 = 1 mm and S1 = 0 mm

These values apply for mounting in aluminium

N1 = 0 mm and S1 = 5 mm or

N1 = 5 mm and S1 = 0 mm

These values apply for mounting in St37.

Wiring accessories

Dimension drawing	Type	Ident. no.	
	RKC4.4T-2/TEL	6625013	Connection cable, female M12, straight, 4-pin, cable length: 2 m, sheath material: PVC, black; cULus approval; other cable lengths and qualities available, see www.turck.com

