

BI8U-Q08-AP6X2-0.2-RS4T/S1589

Inductive Sensor – With WeldGuard™ Coating

Features

- Rectangular, height 8 mm
- Active face on top
- Metal, GD-Zn
- Connector with snap-lock
- Factor 1 for all metals
- Increased switching distance
- Protection class IP68
- Resistant to magnetic fields
- Mountable on metal
- DC 3-wire, 10...30 VDC
- NO contact, PNP output
- Pigtail with male end M12 x 1

Wiring diagram

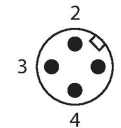
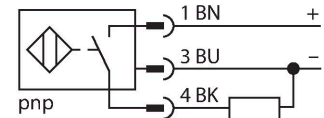

Functional principle

Inductive sensors are designed for wear-free and contactless detection of metal objects. uprox+ sensors have significant advantages due to their patented multi-coil system. They excel thanks to their optimum switching distances, maximum flexibility and operational reliability as well as efficient standardization.

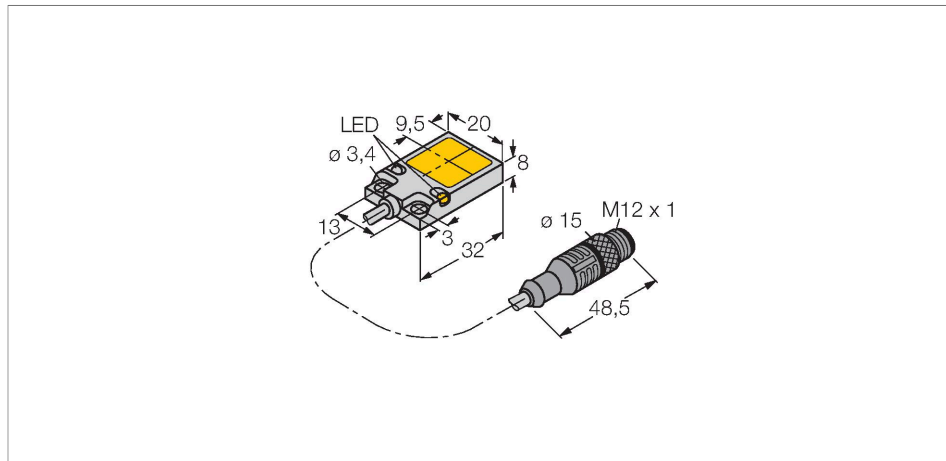

Technical data

Type	BI8U-Q08-AP6X2-0.2-RS4T/S1589
Ident. no.	1662083
Special version	S1589 corresponds to: With weldguard coating
Rated switching distance	8 mm
Mounting conditions	Flush
Secured operating distance	$\leq (0.81 \times S_n)$ mm
Repeat accuracy	$\leq 2\%$ of full scale
Temperature drift	$\leq \pm 10\%$ $\leq \pm 15\%$, $\leq -25\text{ °C}$ v $\geq +70\text{ °C}$
Hysteresis	3...15 %
Ambient temperature	-25...+70 °C
Operating voltage	10...30 VDC
Residual ripple	$\leq 10\% U_{ss}$
DC rated operational current	$\leq 200\text{ mA}$
No-load current	$\leq 15\text{ mA}$
Residual current	$\leq 0.1\text{ mA}$
Isolation test voltage	$\leq 0.5\text{ kV}$
Short-circuit protection	yes / Cyclic
Voltage drop at I_o	$\leq 1.8\text{ V}$
Wire breakage/Reverse polarity protection	yes / Complete
Output function	3-wire, NO contact, PNP
Switching frequency	0.25 kHz

Technical data

Design	Rectangular, Q08
Dimensions	32 x 20 x 8 mm
Housing material	Metal, GD-Zn, Nickel-plated
Active area material	Plastic, PP, yellow
Material coupling nut	metal, CuZn, nickel-plated
Electrical connection	Cable with connector, M12 × 1
Cable quality	Ø 4 mm, Gray, LIF2X11XFHF, TPU, 0.2 m Flame retardant acc. to VDE 0472, part 804B
Core cross-section	3 x 0.25 mm ²
Vibration resistance	55 Hz (1 mm)
Shock resistance	30 g (11 ms)
Protection class	IP68
MTTF	874 years acc. to SN 29500 (Ed. 99) 40 °C
Power-on indication	LED, Green
Switching state	LED, Yellow

Mounting instructions

Mounting instructions/Description

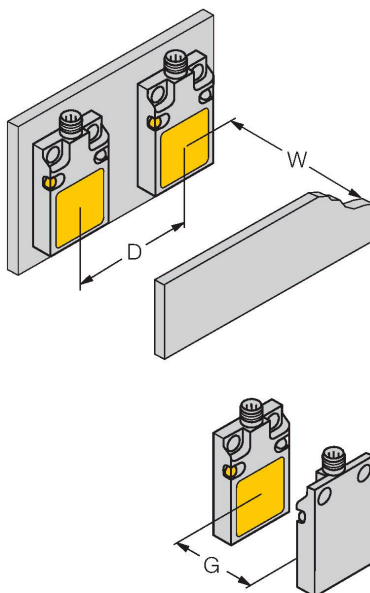

Distance D	40 mm
Distance W	24 mm
Distance G	48 mm
Width active area B	17 mm