

## Flow monitoring

### Immersion sensor without integrated processor

#### FCS-G1/2A4-NA/AL065

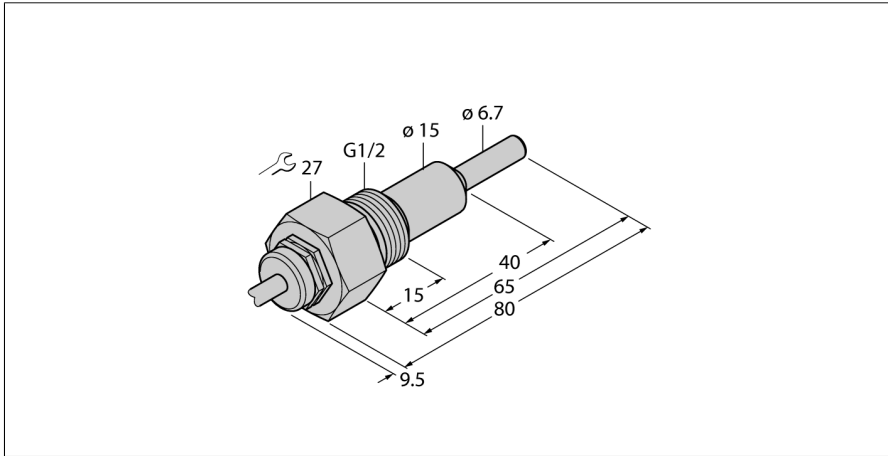

- Sensor for gaseous media
- Calorimetric functionality
- Adjustment via signal processor
- Status indicated via LED chain on signal processor
- Sensor length 65 mm
- Cable device
- 4-wire connection to the processor

#### Wiring Diagram

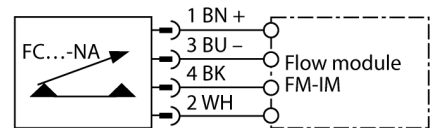

#### Functional principle

Our insertion - flow sensors operate on the principle of thermodynamics. The measuring probe is heated by several °C as against the flow medium. When fluid moves along the probe, the heat generated in the probe is dissipated. The resulting temperature is measured and compared to the medium temperature. The flow status of every medium can be derived from the evaluated temperature difference. Thus TURCK's wear-free flow sensors reliably monitor the flow of gaseous and liquid media.

<b>Type designation</b>	FCS-G1/2A4-NA/AL065
Ident-No.	6870340
<b>Mounting</b>	Immersion sensor
Air Operating Range	0.5...30 m/s
Stand-by time	60 s
Switch-on time	10...120 s
Switch-off time	10...120 s
Temperature jump, response time	25...40 s
Temperature gradient	≤ 1 K/min
Medium temperature	-20...+80 °C
<b>Protection class</b>	IP68
<b>Design</b>	Immersion
Housing material	Stainless steel, V4A (1.4571)
Sensor material	Stainless steel, V4A (1.4571)
Max. tightening torque housing nut	30 Nm
Cable length (L)	2 m
Cable cross section	4 x 0.25 mm <sup>2</sup>
Pressure resistance	20 bar
Process connection	G 1/2"