

Flow monitoring

Immersion sensor with integrated processor

FCS-M18-AP8X/D087

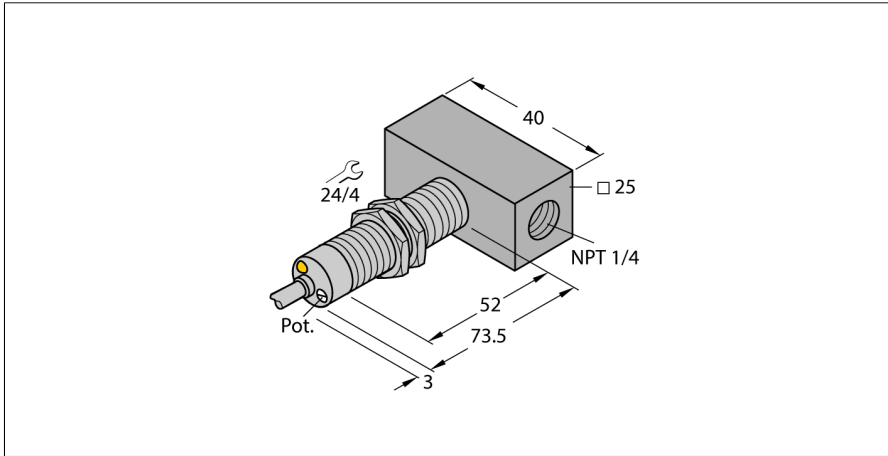

- Sensor for gaseous media
- Calorimetric principle
- Adjustments via potentiometer
- Status display via 2-color LED
- Chrome-plated brass sensor
- 3-wire DC, 19.2...28.8 VDC
- NO contact, PNP output
- Cable device

Wiring Diagram

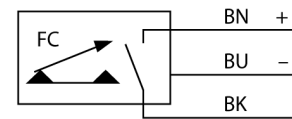

Functional principle

Our insertion - flow sensors operate on the principle of thermodynamics. The measuring probe is heated by several °C as against the flow medium. When fluid moves along the probe, the heat generated in the probe is dissipated. The resulting temperature is measured and compared to the medium temperature. The flow status of every medium can be derived from the evaluated temperature difference. Thus TURCK's wear-free flow sensors reliably monitor the flow of gaseous and liquid media.

Type designation	FCS-M18-AP8X/D087
Ident-No.	6870800
Mounting	Immersion sensor
Air Operating Range	0.5...15 m/s
Switch-on time	typ. 2 s (1...20 s)
Switch-off time	typ. 2 s (1...20 s)
Temperature gradient	≤ 200 K/min
Medium temperature	-20...+70 °C
Ambient temperature	0...+60 °C
Operating voltage	19.2...28.8 VDC
Current consumption	≤ 70 mA
Output function	PNP, NO contact
Rated operational current	0.4 A
Short-circuit protection	yes
Reverse polarity protection	yes
Protection class	IP67
Design	Immersion
Housing material	Metal, CuZn
Sensor material	Brass, brass, nickel-plated
Electrical connection	Cables
Cable length (L)	2 m
Cable cross section	3 x 0.5 mm ²
Process connection	NPT 1/4" female thread
MTTF	637 years acc. to SN 29500 (Ed. 99) 40 °C
Switching state	2-color LED, Red/Green