

**Flow Rate Measurement**  
**Inline sensor with integrated processor**  
**FTCI-3/4D15A4P-2LUX-H1141/D505**

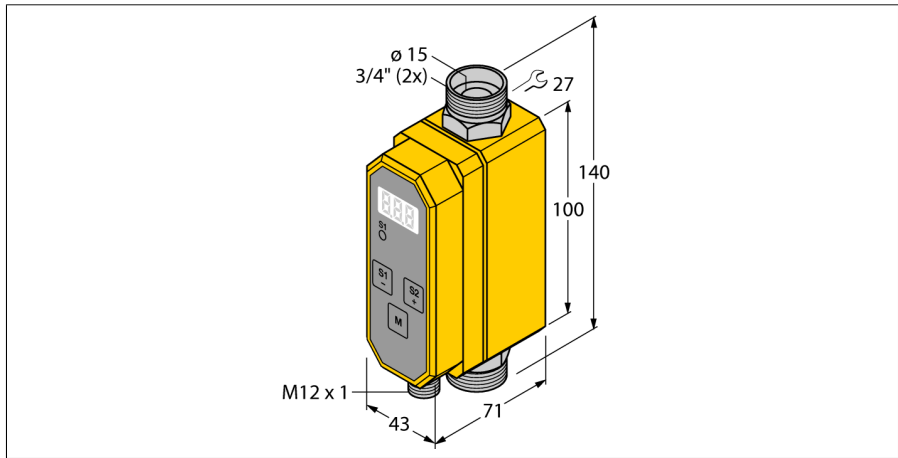

- Compact inline flow sensor
- Calorimetric principle
- Monitoring of flow rate
- Monitoring of the medium temperature
- For water/glycol mix
- Parametrized via button
- Protected by software code
- Analog output flow 0... 10 VDC
- Analog output temperature 0...10 VDC
- Electrical connection M12 x 1

**Wiring Diagram**

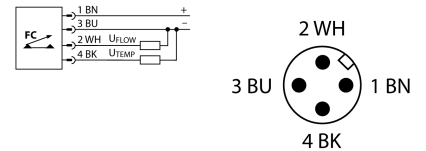

<b>Type designation</b>	FTCI-3/4D15A4P-2LUX-H1141/D505
Ident-No.	6870841
<b>Mounting</b>	Inline sensor
Application area	flow rate/temperature monitoring of water or water/glycol mix
Flow operating range	3.8...45.4 l/min
Switch-on time	2...8 s
Switch-off time	2...8 s
Medium temperature	-10...+90 °C
<b>Operating voltage</b>	21.6...26.4 VDC
Current consumption	≤ 100 mA
Output function	Analog output
Short-circuit protection	yes
Reverse polarity protection	yes
Voltage output	0...10V
Load resistance voltage output	≥ 10 kΩ
Protection class	IP65
<b>Design</b>	Inline
Housing material	Plastic, PBT
Sensor material	Stainless steel, V4A (1.4571)
Electrical connection	Connector, M12 x 1
Pressure resistance	20 bar
<b>Programming options</b>	glycol concentration, flow rate correction, mean value, access code, reference check

**Functional principle**

The FTCTIs from TURCK monitor flow rates of liquids passing through the sensor reliably and wear-free. These sensors are designed for high-precision flow rate measurement rather than simple flow monitoring tasks.

Based on the thermodynamic principle, electrical energy is converted in heat energy. The heat generated in the probe is conducted away by the flowing medium. The dissipated heat quantity is used as a direct measure for the medium's flow speed. The integrated microprocessor evaluates the data and calculates the flow rate. Based on the applied principle, the user is also indicated the media temperature.

In addition to the standardized electrical output signals for industrial applications, the TURCK flow meters also indicated the current flow rate on its 3-digit 7-segment display.