

## Flow monitoring

### Immersion sensor without integrated processor

#### FCS-N1/2A4-NA-H1141/L060

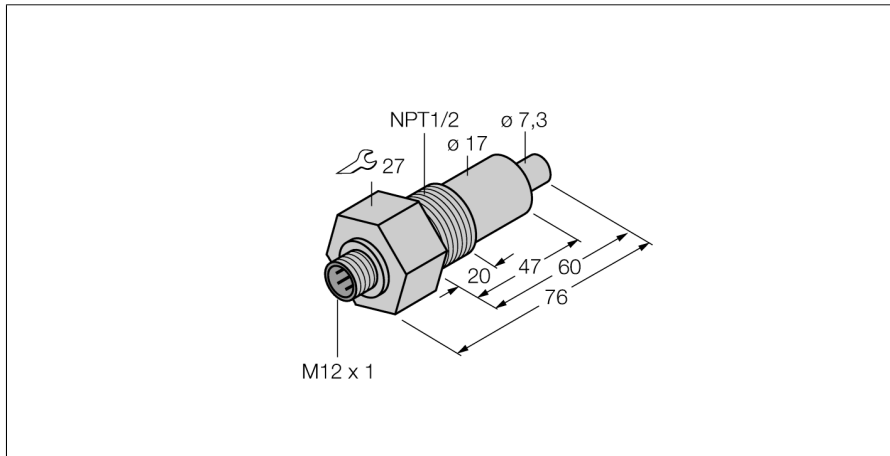

- Sensor for liquid media
- Calorimetric functionality
- Adjustment via signal processor
- Status indicated via LED chain on signal processor
- Sensor length 60 mm
- Connector device, M12 × 1
- 4-wire connection to the processor

#### Wiring Diagram

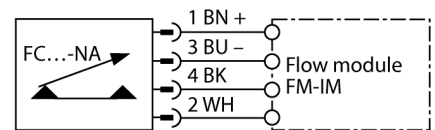

#### Functional principle

Our insertion - flow sensors operate on the principle of thermodynamics. The measuring probe is heated by several °C as against the flow medium. When fluid moves along the probe, the heat generated in the probe is dissipated. The resulting temperature is measured and compared to the medium temperature. The flow status of every medium can be derived from the evaluated temperature difference. Thus TURCK's wear-free flow sensors reliably monitor the flow of gaseous and liquid media.

**Type designation** FCS-N1/2A4-NA-H1141/L060  
**Ident-No.** 6871310

**Mounting** Immersion sensor  
Water Operating Range 1...150 cm/s  
Oil Operating Range 3...300 cm/s  
Stand-by time typ. 8 s (2...15 s)  
Switch-on time typ. 2 s (1...15 s)  
Switch-off time typ. 2 s (1...15 s)  
Temperature jump, response time max. 12 s  
Temperature gradient ≤ 250 K/min  
Medium temperature -20...+80 °C

**Protection class** IP67

**Design** Immersion  
Housing material Stainless steel, V4A (1.4571)  
Sensor material Stainless steel, V4A (1.4571)  
Max. tightening torque housing nut 30 Nm  
Electrical connection Connector, M12 × 1  
Pressure resistance 100 bar  
Process connection NPT ½"