

**Ultrasonic Sensor
Retroreflective Sensor
RU100L-M18M-UP8X2-H1151**

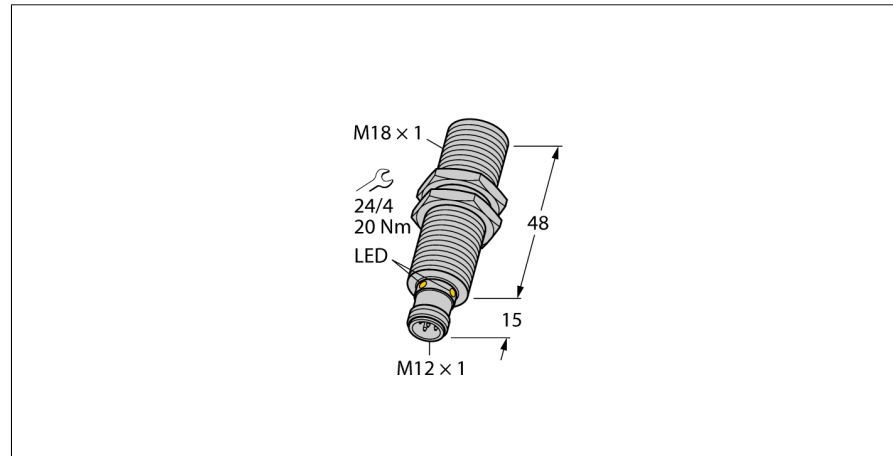

- Smooth sonic transducer face
- Cylindrical housing M18, potted
- Connection via M12 x 1 male
- Temperature compensation
- Teaching range 15...98cm
- Resolution: 1 mm
- Sonic cone angle: 16°
- 1 x switching output, PNP
- Teachable settings
- NO/NC programmable

Wiring Diagram

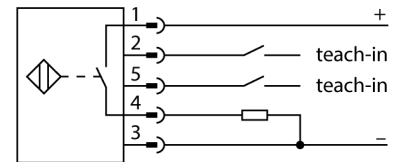

Functional principle

Ultrasonic sensors capture a multitude of objects contactlessly and wear-free with ultrasonic waves. It does not matter whether the object is transparent or opaque, metallic or non-metallic, firm, liquid or powdery. Even environmental conditions such as spray, dust or rain hardly affect their function.

The sonic cone diagram indicates the detection range of the sensor. In accordance with standard EN 60947-5-2, quadratic targets in a range of sizes (20 x 20 mm, 100 x 100 mm) and a round rod with a diameter of 27 mm are used.

Important: The detection ranges for other targets may differ from those for standard targets due to the different reflection properties and geometries.

Sonic Cone

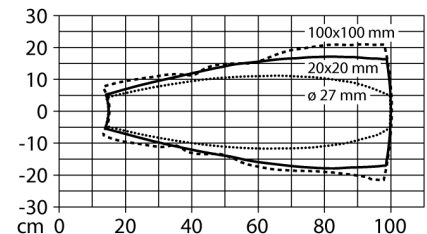

Type designation	RU100L-M18M-UP8X2-H1151
Ident-No.	1610077
Function	Ultrasonic retroreflective sensor
Range	150...1000 mm
minimum switching range	10 mm
Ultrasound frequency	200 kHz
Repeat accuracy	0.15 % of full scale
Temperature drift	1.5% of full scale
Linearity error	≤ ± 0.5 %
Edge lengths of the nominal actuator	100 mm
Approach speed	≤ 8 m/s
Pass speed	≤ 2 m/s
Operating voltage	15...30 VDC
Residual ripple	10 % U _s
DC rated operational current	≤ 150 mA
No-load current I ₀	≤ 50 mA
Load resistance	≤ 1000 Ω
Residual current	≤ 0.1 mA
Response time typical	90 ms
Readiness delay	300 ms
Output function	NO/NC, PNP
Output 1	Switching output
Switching frequency	6.9 Hz
Hysteresis	≤ 10 mm
Voltage drop at I _L	≤ 2.5 V
Short-circuit protection	yes/ Cyclic
Reverse polarity protection	yes
Wire breakage protection	yes
Design	Threaded barrel, M18
Radiation direction	straight
Dimensions	63 x Ø 18 mm
Housing material	Metal, CuZn, Nickel-plated
Transducer material	Plastic, Epoxyd resin and PU foam
Electrical connection	Connector, M12 x 1, 5-wire
Protection class	IP67
Ambient temperature	-25...+70 °C
Storage temperature	-40...+80 °C
Declaration of conformity EN ISO/IEC	EN 60947-5-2
Vibration resistance	IEC 60068-2
MTTF	281 years
MTTF note	acc. to SN 29500 (Ed. 99) 40 °C
Switching state	LED, Yellow
Object detected	LED, Green

Ultrasonic Sensor

Retroreflective Sensor

RU100L-M18M-UP8X2-H1151

Mounting instructions/Description

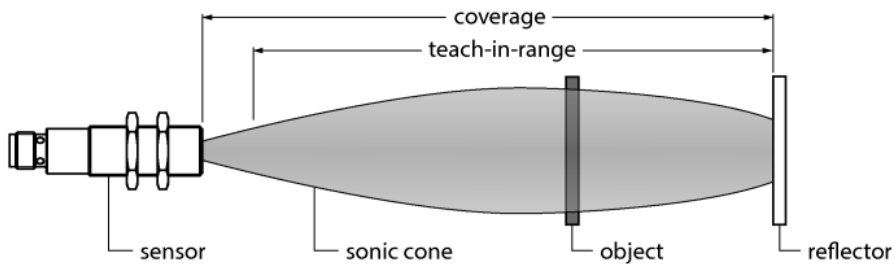

Teaching the reflector position

The ultrasonic sensor features a switching output with a teachable switching range. The green and yellow LEDs indicate whether the sensor has detected the object.

A switching range is taught in. This must be within the detection range. In this operating mode, the taught reflector position is detected permanently without an object.

Easy-Teach

- Connect the teach adapter TX1-Q20L60 between the sensor and connection cable
 - Stationary reflector within the detection range
 - Press and hold button for at least 2 s against Gnd
- After a successful teach-in, the green LED flashes at 3 Hz and the sensor runs automatically in normal mode.
- To invert the output function, press and hold the button against the Ub for 2...7s

LED response

In standard operating mode, the two LEDs indicate the switching state of the sensor.

- Green: reflector within the detection range
- Yellow: object between the sensor and reflector

**Ultrasonic Sensor
Retroreflective Sensor
RU100L-M18M-UP8X2-H1151**

Accessories

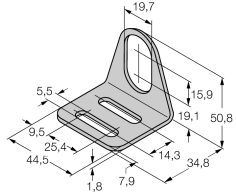
Type code	Ident-No.	Description	Dimension drawing
MW-18	6945004	Mounting bracket for threaded barrel sensors; material: Stainless steel A2 1.4301 (AISI 304)	

Function accessories

Type code	Ident-No.	Description	Dimension drawing
TX1-Q20L60	6967114	Teach adapter for inductive encoders, linear position, angle, ultrasonic and capacitive sensors	