

Ultrasonic Sensor
Diffuse Mode Sensor
RU200-CP40-LIU2N8X2T/S10

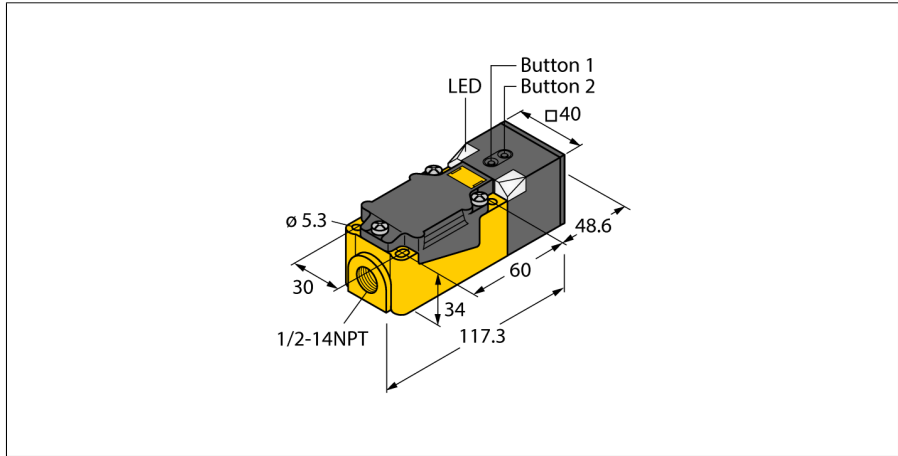

- Separate transducers for transmitter and receiver
- Rectangular housing 40 x 40 x 166 mm
- Connection via screw terminals
- Terminal chamber for cable gland NPT
- Teach range adjustable via button
- Blind zone: 5 cm
- Range: 200 cm
- Resolution: 1 mm
- Sonic cone angle: 60°
- 1 x switching output, NPN
- NO/NC programmable
- 1 x analog output, 4..20mA/ 0..10 V

Type designation	RU200-CP40-LIU2N8X2T/S10
Ident-No.	1610091
Special version	S10 corresponds to: Mounting base with 1/2-14NPT thread
Function	Ultrasonic diffuse mode sensor
Range	50...2000 mm
Resolution	1 mm
minimum measuring range	200 mm
minimum switching range	20 mm
Ultrasound frequency	120 kHz
Repeat accuracy	0.25 % of full scale
Edge lengths of the nominal actuator	100 mm
Approach speed	≤ 3 m/s
Pass speed	≤ 3 m/s
Operating voltage	15...30 VDC
Residual ripple	10 % U _s
DC rated operational current	≤ 150 mA
No-load current I ₀	≤ 50 mA
Load resistance	≤ 1000 Ω
Residual current	≤ 0.1 mA
Response time typical	160 ms
Readiness delay	300 ms
Output function	NO/NC, NPN
Output 1	Switching output
Output 2	Analog output
Current output	4...20 mA
Load resistance, current output	≤ 0.5 kΩ
Voltage output	0...10V
Load resistance voltage output	≥ 1 kΩ
Switching frequency	3 Hz
Hysteresis	≤ 20 mm
Voltage drop at I ₀	≤ 2.5 V
Short-circuit protection	yes/ Latching
Reverse polarity protection	yes
Wire breakage protection	yes
Design	Rectangular, CP40
Radiation direction	straight
Dimensions	166 x 40 x 40 mm
Housing material	Plastic, PBT-GF30-V0
Electrical connection	Terminal chamber, Terminal box with cable gland, 4-wire
Protection class	IP40
Ambient temperature	0...+70 °C
Declaration of conformity EN ISO/IEC	EN 60947-5-7

Wiring Diagram

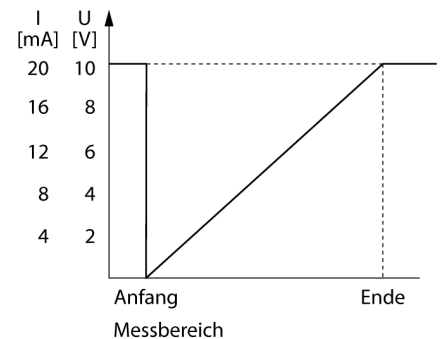
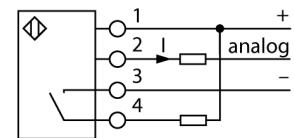

Functional principle

Ultrasonic sensors capture a multitude of objects contactlessly and wear-free with ultrasonic waves. It does not matter whether the object is transparent or opaque, metallic or non-metallic, firm, liquid or powdery. Even environmental conditions such as spray, dust or rain hardly affect their function.

The sonic cone diagram indicates the detection range of the sensor. In accordance with standard EN 60947-5-7, quadratic targets in a range of sizes (20 x 20 mm, 100 x 100 mm) and a round rod with a diameter of 27 mm are used.

Important: The detection ranges for other targets may differ from those for standard targets due to the different reflection properties and geometries.

Sonic Cone

Ultrasonic Sensor
Diffuse Mode Sensor
RU200-CP40-LIU2N8X2T/S10

Switching state	LED, Yellow
Object detected	LED, Green

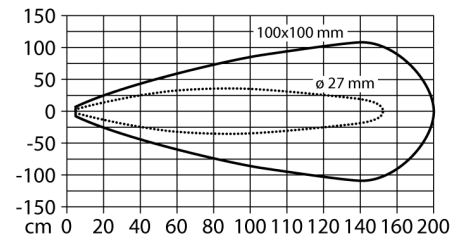

**Ultrasonic Sensor
Diffuse Mode Sensor
RU200-CP40-LIU2N8X2T/S10**

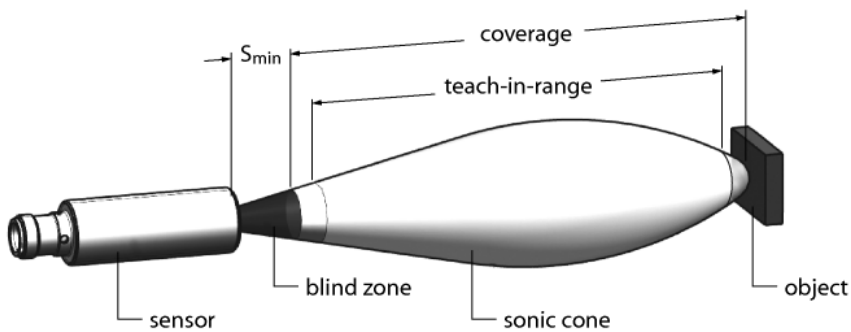

Setting the limits

The ultrasonic sensor has an analog and a switching output with teachable measuring and switching range. Teaching via buttons on the housing. The green and yellow LED indicate whether the sensor has detected an object.

Various functions such as single switchpoint, window mode or reflection mode to a fixed target can be taught. Further information is described in the operating instructions. How to set the window mode is described below. The limits of the window may be selected freely within the detection range.

- For the first limit value, place object accordingly
- Press and hold button 1 to select output 1 or 2 for 2 or 8 s against Gnd
- Press and hold button 1 for at least 8 s
- For the second limit value, place object accordingly
- Press and hold button 1 for at least 2 s

LED response

Successful teaching is indicated by a fast flashing green LED. Thereafter, the sensor automatically runs in normal operating mode. Unsuccessful teaching is indicated by the LED flashing alternately green and yellow. In normal operating mode both LEDs signal the switching state of output 1.

- green: object is in the detection range but not in the switching range
- yellow: object is in the switching range
- off: object is outside the detection range or signal loss