

TTMS-206A-G1/2-LI6-H1140-L250-50/150

Temperature Detection – With Current Output

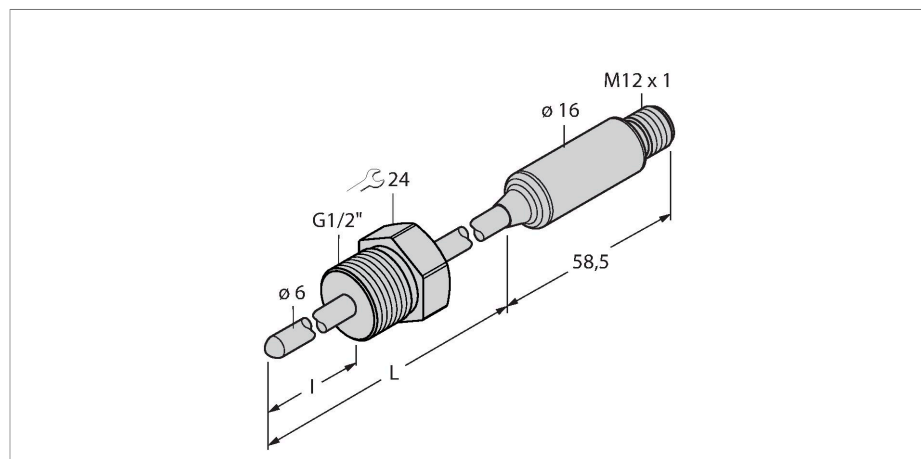

Features

- Miniature design
- Analog output 4...20 mA
- Factory setting -50...150°C (other settings on request)
- Process connection G1/2" male thread
- Bendable probe (min. bending radius: 3x outer diameter; excluding 30-mm probe tip)

Wiring diagram

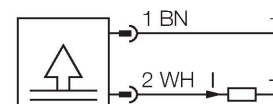

Technical data

Type	TTMS-206A-G1/2-LI6-H1140-L250-50/150
Ident. no.	100004225
Temperature range	
Measuring range	-50...150 °C
Temperature operating range	-58...302 °F
Measuring element	Pt-1000 probe, DIN EN 60751, class A
Response time	t 0.5 = 6 s / t 0.9 = 15 s in water at 0.2 m/s
Bar length (L)	300 mm
Immersion length (I)	250 mm
Power supply	
Operating voltage	5...32 VDC
Current consumption	≤ 20 mA
Short-circuit/reverse polarity protection	yes / yes
Protection type and class	IP67 / III
Outputs	
Output 1	Analog output
Output function	Analog output
Analog output	
Current output	4...20 mA
Load	≤ 0.86 kΩ @24 VDC [R _{Load} =(V _{supply} - 5 V)/22 mA] kΩ
Accuracy (Lin. + Hys. + Rep.)	± 0.2 K

Functional principle

All devices of the miniature transmitter series TTMS are made of stainless steel 1.4404 (AISI 316L). They are available with integrated probe or with M12 probe connection. Due to the integrated electronics, the limited temperature range must be observed, especially in the area of the M12 connector. Furthermore, the devices feature a current output (2-wire, 4...20 mA), a switching output and communication via IO-Link.

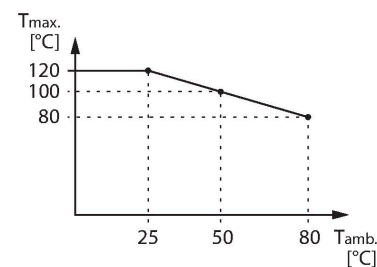

Technical data

Temperature behaviour	
Temperature coefficient zero point Tk0	± 0.1 % of full scale/10 K
Temperature coefficient span T _{KS}	± 0.1 % of full scale/10 K
Ambient conditions	
Ambient temperature	-40...+80 °C
Storage temperature	-40...+80 °C
Housing	
Housing material	Stainless steel, 1.4404 (AISI 316L)
Sensor material	Stainless steel, 1.4404 (AISI 316L)
Process connection	G 1/2" male thread
Process Pressure	100 bar
Electrical connection	Connector, M12 × 1
Reference conditions acc. to IEC 61298-1	
Temperature	15...+25 °C
Atmospheric pressure	860...1060 hPa abs.
Humidity	45...75 % rel.
Auxiliary power	24 VDC
MTTF	162 years acc. to SN 29500 (Ed. 99) 40 °C