

NIMFE-M12/6.2L101-UN6X-H1141

Magnetic Field Sensor

For Detection of Ferromagnetic Parts

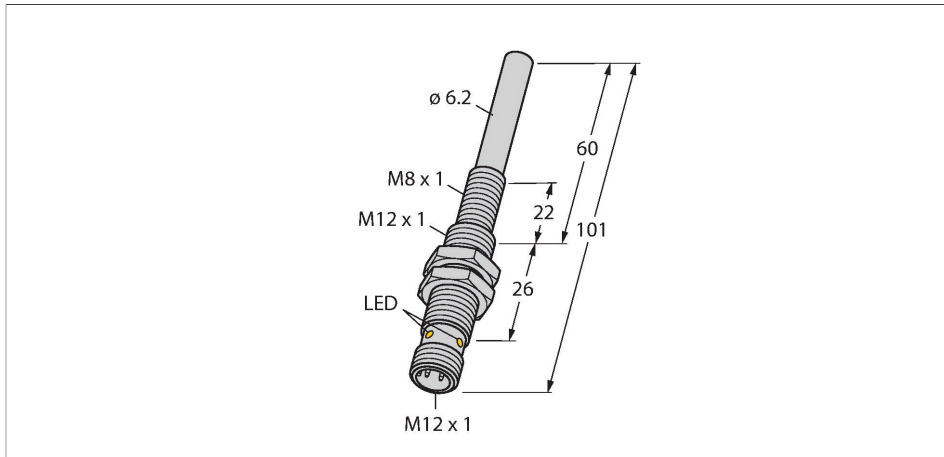

Technical data

Type	NIMFE-M12/6.2L101-UN6X-H1141
Ident. no.	1600611
Ambient temperature	-25...+70 °C
Operating voltage	10...30 VDC
Residual ripple	≤ 10 % U _{ss}
DC rated operational current	≤ 200 mA
No-load current	≤ 15 mA
Residual current	≤ 0.1 mA
Isolation test voltage	≤ 0.5 kV
Short-circuit protection	yes / Cyclic
Voltage drop at I _a	≤ 1 V
Wire breakage/Reverse polarity protection	yes / Complete
Output function	3-wire, Connection programmable, NPN
Design	Threaded barrel, M12 × 1
Dimensions	101 mm
Housing material	Metal, CuZn, Chrome-plated
Active area material	Metal, CuZn, chrome-plated
Max. tightening torque of housing nut	10 Nm
Electrical connection	Connector, M12 × 1
Vibration resistance	55 Hz (1 mm)
Shock resistance	30 g (11 ms)
Protection class	IP67

Features

- Threaded barrel, M12/M8
- Chrome-plated brass
- DC 3- wire, 10...30 VDC
- Programmable (NC/NO) with teach adapter VB2-SP1
- M12 x 1 connector

Wiring diagram

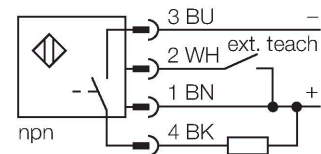

Functional principle

The weld sensors are available in different versions, with different signal intensities and diameters. Ferromagnetic parts which differ strongly in their material properties and diameters can thus be detected. A target part has to be located within the so called sensitive area in order to be detected. The internal sensor signal reaches the maximum intensity if the sensitive area is completely covered by the target. Partial coverage is also possible.

Sensitive area S = 11mm
 Within this area the sensor signal changes when components are connected.

Maximum range M = 14mm
 In case of complete coverage of the sensitive area the maximum signal intensity is achieved.

NIMFE-M12/6.2L101-UN6X-H1141 | 12/03/2020 06-37 | technical changes reserved

Technical data

MTTF 874 years acc. to SN 29500 (Ed. 99) 40 °C

Power-on indication LED, Green

Switching state LED, Yellow

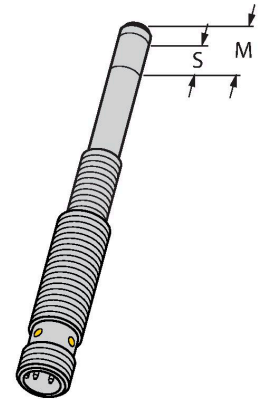

Mounting instructions

Mounting instructions/Description

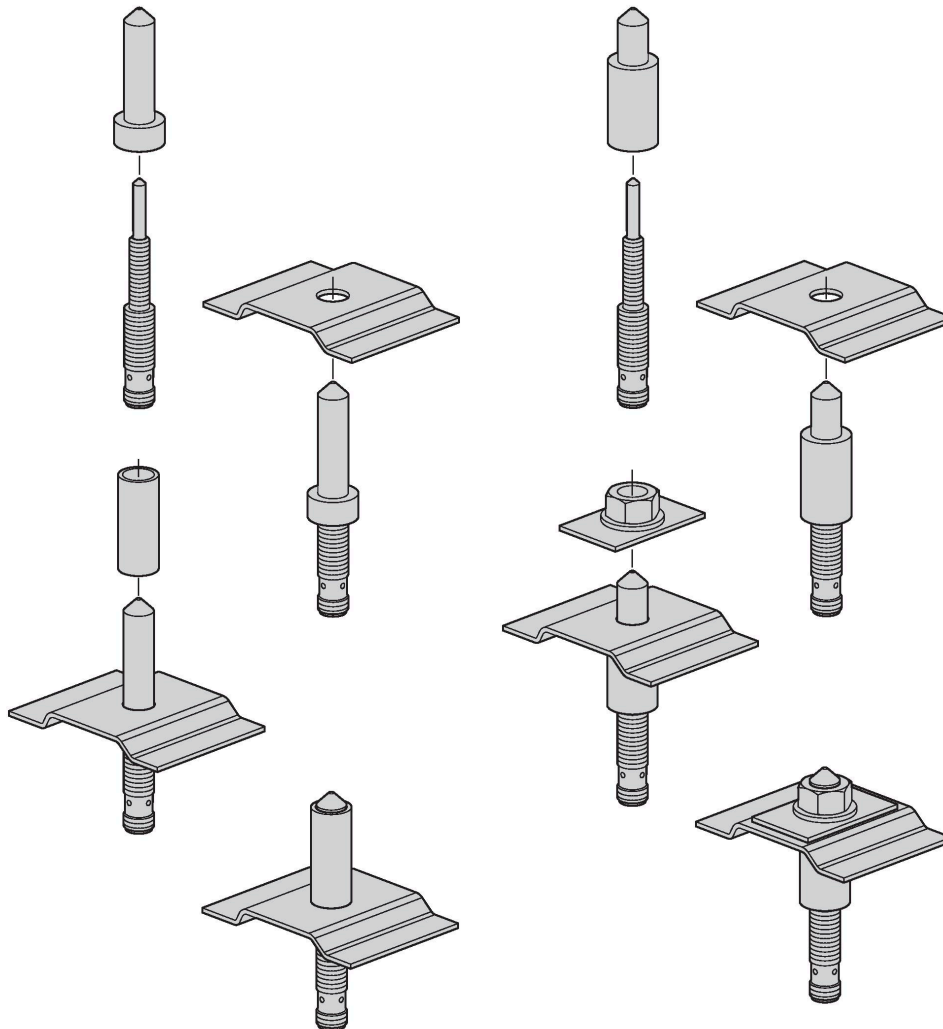

The magnetic field sensor is especially suited for the detection of welding nuts as well as spacer or reinforcing sleeves. The parts to be detected must always consist of ferromagnetic material, so that a proper function can be guaranteed. Most applications need center bolts to tack the welding nuts and reinforcing sleeves in place and thus provide mechanical protection of the sensors. These bolts have to be made of non-ferromagnetic material, like stainless steel for example. Center bolts are not available at Turck, as these have to be individually produced for and adjusted to the correspondent application.

The welding nut sensor easily detects ferritic targets with diameters between 10 mm and 20 mm.

Accessories

BSS-12

6901321

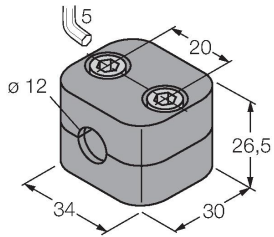

Mounting clamp for smooth and threaded barrel sensors; material: Polypropylene

VB2-SP1

A3501-29

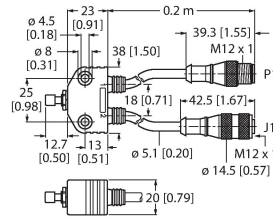

Teach adapter