

Data sheet for three-phase Squirrel-Cage-Motors SIMOTICS

Motor type: **GP100** FS: 215T - 4p - 10 hp -

Client order no.	Item-No.	Offer no.
Order no.	Consignment no.	Project

Remarks

Electrical data without

U [V]	Δ/Y	f [Hz]	P [HP]	P [kW]	n [rpm]	I Load [Amps]					Nom. Eff Load [%]			Pwr. Factor Load [%]			Torque [lb-ft]	T _A /T _N LRT [%]	T _k /T _N BDT [%]
						4/4	3/4	1/2	0	LRC	4/4	3/4	2/4	4/4	3/4	2/4			
460	Y	60	10.00	7.50	1,755	12.50	10.00	8.00	6.10	81.0	91.7	92.2	91.7	81.7	76.2	63.8	30.0	270	410
230	YY	60	10.00	7.50	1,755	25.00	19.99	16.00	12.20	162.0	91.7	92.2	91.7	81.7	76.2	63.8	30.0	270	410

Frame Type: 215T	Type of constr.: (A) Foot mounted - End shield	Ins. Cl.: Standard Class F Insulation	Motor Prot.: (A) Without Protection	NEMA Des.: B	S.F.: 1.15
Mtr. WT: 166		Temp. Rise Cl.: B	Amb. Temp.: + 40 to -20 °C @1000 m	kVA: H	I.P.: 55

Mechanical data

Sound level (SPL / SWL) at 60 Hz	57.0 dB(A) / 69.0 dB(A)		Thickener	Polyurea					
Octave Band Center Frequencies Hertz			Safe Stall Time Hot	20 s					
	250	500	1000	2000	4000	8000	Hz	Safe Stall Time Cold	36 s
SPL@3	37.0	44.0	54.0	53.0	44.0	35.0	dB(A)	Frame material	cast iron
Moment of inertia	0.9 Lb-ft ²		Color, paint shade	Standard Paint - RAL7030					
Ext Load Inertia Capability:	51.0 Lb ft ²		Coating (paint finish)	Standard Alkyed + Epoxy (C2)					
Bearings			Ventilation Type						
Bearing DE NDE	6208 ZZ C3 S0		6208 ZZ C3 S0	Method of cooling	TEFC				
Bearing_Type	Ball Bearing		Ball Bearing	Direction of rotation	Bidirectional				
AFBMA:	40BC02JPP30		40BC02JPP30	Fan Material	Polypropylen				
Grease			VFD	CT: 4:1 VT: 20:1					
Capacity	0.30 oz		0.30 oz	Space heaters	without				
Grease Type:	Exxon Mobile EM		Brake:	without					

Terminal box

Lead Wire Connection	9 LEAD - WYE				Terminal box position	(3) F-1, Standard Floor Mount, T. Box LHS
Voltage	L1	L1	L1	Connected together	Material of terminal box	Aluminium
LOW	T1 T7	T2 T8	T3 T9	T4 T5 T6	Cable entry	1" NPT
HIGH	T1	T2	T3	T4 T7-T5 T8-T6 T9		

Notes:

I_r/I_N = locked rotor current / current nominal
M_r/M_N = locked rotor torque / torque nominal
M_d/M_N = break down torque / nominal torque

3) Value is valid only for DOL operation with motor design IC411
2) at rated power / at full load

responsible dep. DI MC LVM	technical reference	created by DT Configurator	approved by	<i>Technical data are subject to change! There may be discrepancies between software and hardware versions</i>
-------------------------------	---------------------	-------------------------------	-------------	--

	document type datasheet	document status released	customer	
	title 1LE2221-2AB21-6AA3-Z B09+F36	document number	rev. 01	creation date 2021-04-22 07:37
© Siemens AG 2021				Page 1/2

Data sheet for three-phase Squirrel-Cage-Motors SIMOTICS

Motor type: GP100 FS: 215T - 4p - 10 hp -

Special design

B09 Export packing sea freight - Siemens standard F36 Electrical duplicate - (routine test)

Notes:

responsible dep. DI MC LVM	technical reference	created by DT Configurator	approved by	<i>Technical data are subject to change! There may be discrepancies between software and hardware unless</i>
-------------------------------	---------------------	-------------------------------	-------------	--

	document type datasheet	document status released	customer	
	title 1LE2221-2AB21-6AA3-Z B09+F36	document number	rev. 01	creation date 2021-04-22 07:37
© Siemens AG 2021				Page 2/2

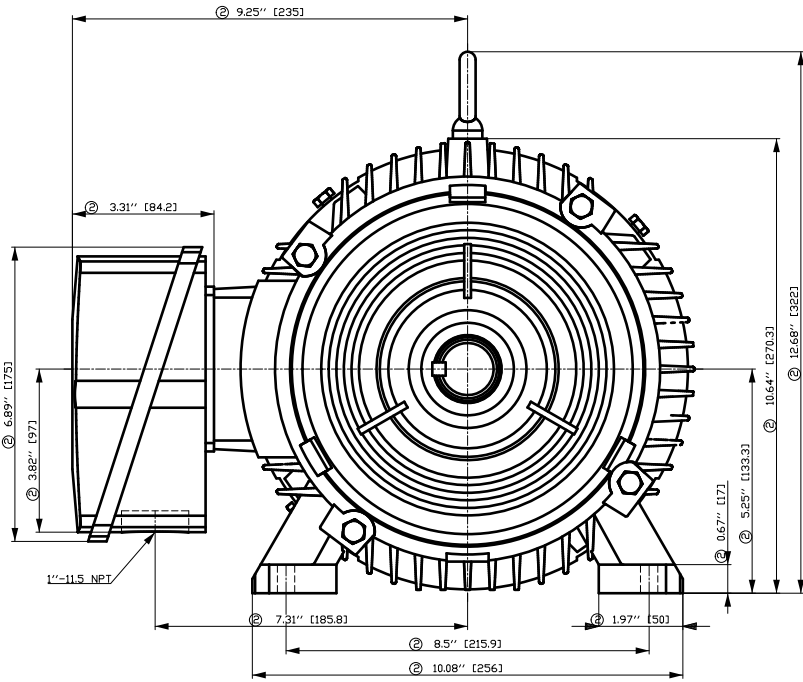

① Tolerances according to NEMA std.

② All these dimensions corresponding to assemblies and castings shall have a tolerance as per DIN standard 1686-GTB 19.

③ Not according to NEMA std.

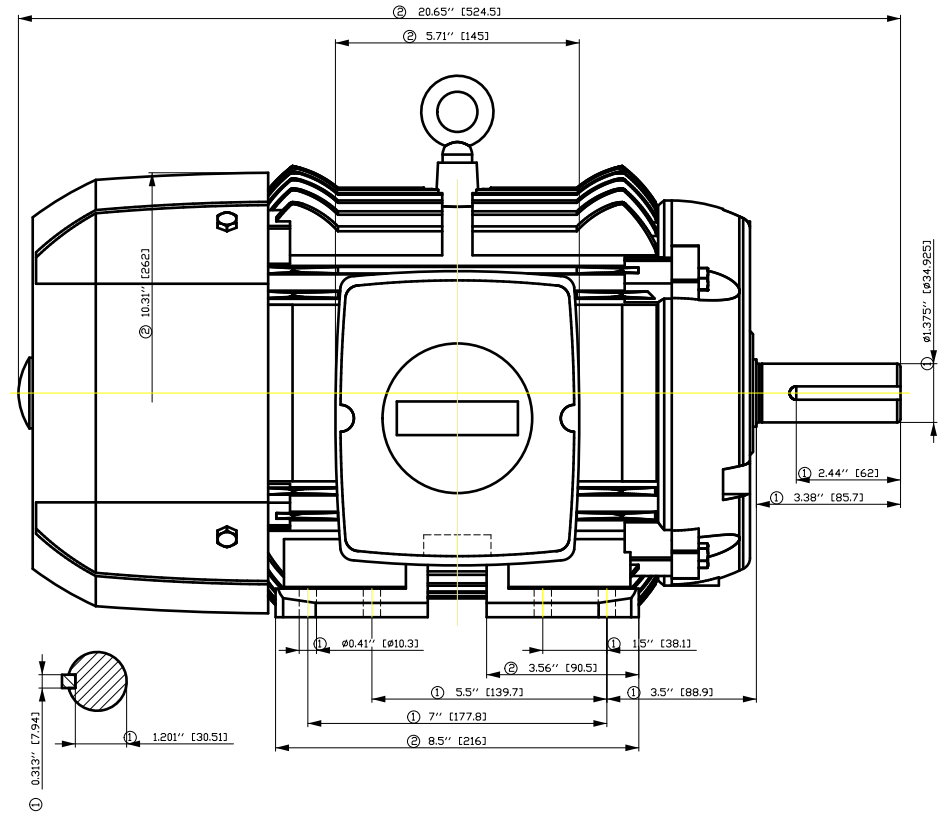

Tolerance	Surface	Material	Weight	Scale
			É	{ {
FŠÖGGFÉÖÖGFÉ ÖEÉÉZ ÖEÉÉH	Author Creator Approval Department Change Order	Öä ^)•ä) æ/æ ä* T æ : ^æ@ }*		
	Doc. State	MLFB	Doc. Type	/
SIEMENS	Revision	Item No	Paper Size	CH
© Siemens AG 2018	Index	Doc No	1st Language	^)
	Project No	Ref No	2nd Language	ä^
	É	É	Sheet	F of F

SIEMENS INDUSTRY, INC.

HP 10 VOLTS < 600V RPM 1800 TYPE GP100
HZ 60 PHASE 3 FRAME 215T NEMA B

TORQUE & CURRENT VS. SPEED

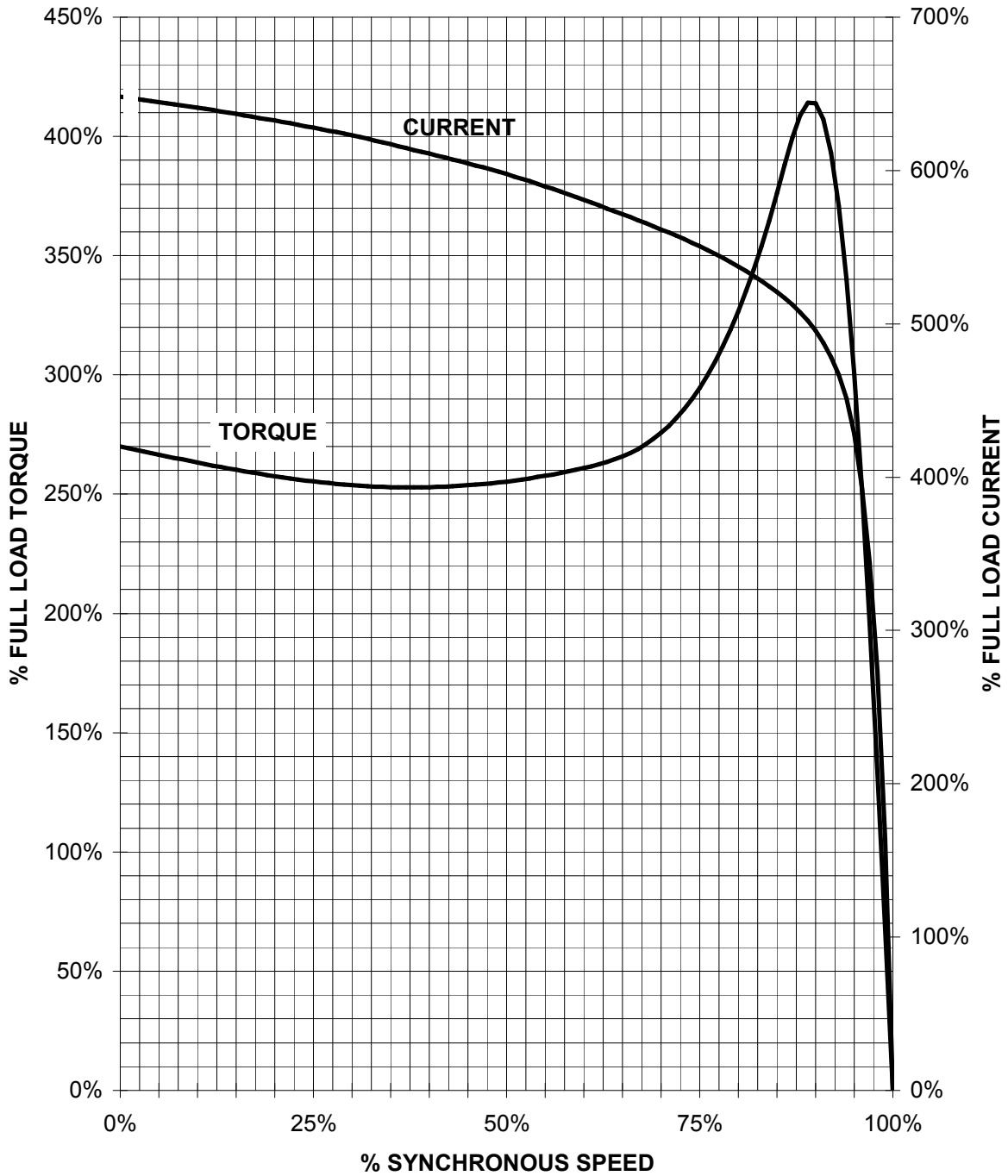

CUSTOMER: _____ ORDER#: _____

Main terminal diagram

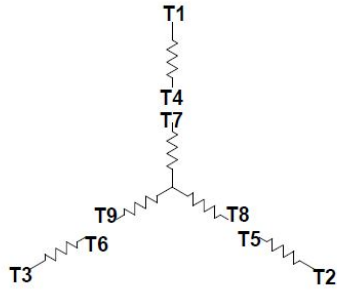

9 LEAD WYE						
Volts	LINES			CONNECTED TOGETHER	CONN.	
	L1	L2	L3			
LOW	T1 T7	T2 T6	T3 T9	T4 T5 T6	YY	
HIGH	T1	T2	T3	T4 T7-T5 T8-T6 T9	Y	

responsible dep. DI MC LVM	technical reference	created by	approved by	Project
SIEMENS	document type Wiring Diagram	document status free		customer
	title 1LE2221-2AB21-6AA3-Z B09+F36	document number		
© Siemens AG 2019	rev. 01	creation date 12/03/2019	language en	Page 1/1