

BD2-AK03X/LSD-AE63-N TAP-OFF UNIT 63A / 1X 3 POLE  
WITH CIRCUITBREAKER 3VL2706 ROTARY DRIVE

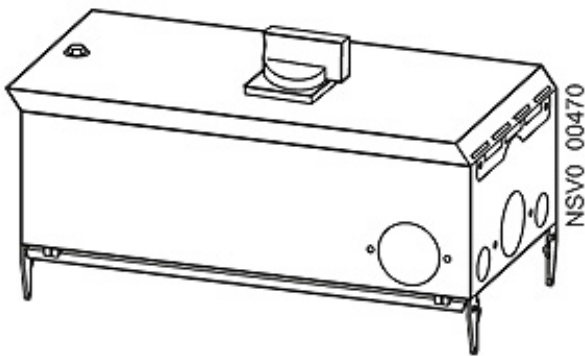

Similar to image

### General technical details:

<b>Product designation</b>		tap-off unit for BD2 busbar trunking system
<b>Product-type designation</b>		BD2-AK03X/LSD-AE63-N
<b>Product function / phase selection</b>		No
<b>Operating current</b>		
<ul style="list-style-type: none"> <li>• for circuit 1</li> <li> <ul style="list-style-type: none"> <li>• at 50 Hz / for AC / rated value / maximum</li> <li>• at 60 Hz / for AC / rated value / maximum</li> </ul> </li> </ul>	A A	63 63
<b>Operating frequency</b>		
<ul style="list-style-type: none"> <li>• rated value</li> </ul>	Hz	50 ... 60
<b>Operating voltage</b>		
<ul style="list-style-type: none"> <li>• at 50 Hz / at AC / rated value / maximum</li> <li>• at 60 Hz / at AC / rated value / maximum</li> </ul>	V V	400 400
<b>Number of CEE sockets</b>		0
<b>Number of safety sockets</b>		0
<b>Number of other sockets</b>		0
<b>Number of conductors / without PE</b>		0

### Mechanical design:

<b>Design of the socket</b>		Other
-----------------------------	--	-------

<b>Product component / locking</b>		Yes
<b>Length</b>	mm	458
<b>Width</b>	mm	214
<b>Height</b>	mm	243
<b>Color</b>		light grey
<b>RAL color number</b>		RAL 7035
<b>Product component / outgoing unit for mounting in devices</b>		No
<b>Conductor cross section that can be connected</b> • in the outgoing unit	mm <sup>2</sup>	2.5 ... 70

#### Outgoing unit:

<b>Design of the outgoing unit</b>		cable entry
<b>Execution of short-circuit and overloading protection / in the outgoing unit</b>		3-pole 63 A circuit-breaker with rotary drive
<b>Size of the outgoing feeder</b>		03
<b>Number of poles / of the outgoing feeder</b>		5

#### Ambient conditions:

<b>Protection class IP</b>		IP54
----------------------------	--	------

#### Further information:

##### Information- and Downloadcenter (Catalogs, Brochures,...)

<http://www.siemens.com/lowvoltage/catalogs>

##### Global Industry Mall (Online ordering system)

<http://www.siemens.com/lowvoltage/mall>

##### Service&Support (Manuals, Certificates, Characteristics, FAQs,...)

<http://support.automation.siemens.com/WW/view/en/BVP:610407/all>

##### Image database (product images, 2D dimension drawings, 3D models, device circuit diagrams, ...)

[http://www.automation.siemens.com/bilddb/cax\\_en.aspx?mlfb=BVP:610407](http://www.automation.siemens.com/bilddb/cax_en.aspx?mlfb=BVP:610407)

last change:

Jul 7, 2014