



Main

Range of product	Modicon M340 automation platform
Product or component type	Analog input module
Electrical connection	1 connector 28 ways
Isolation between channels	Non isolated
Input level	High level
Analogue input number	8
Analogue input type	Voltage 1...5 V Voltage 0...5 V Voltage 0...10 V Voltage +/- 5 V Voltage +/- 10 V Current 4...20 mA Current 0...20 mA Current +/- 20 mA

Complementary

Analog/Digital conversion	16 bits
Analogue input resolution	15 bits + sign
Input impedance	10 MOhm
Permitted overload on inputs	+/- 30 mA +/- 20 mA +/- 30 V 1...5 V +/- 30 V 0...5 V +/- 30 V 0...10 V +/- 30 V +/- 5 V +/- 30 V +/- 10 V +/- 30 mA 4...20 mA +/- 30 mA 0...20 mA
Internal conversion resistor	250 Ohm
Precision of internal conversion resistor	0.1 % - 15 ppm/°C
Type of filter	First order digital filtering
Fast read cycle time	1 ms + 1 ms x number of channels used
Nominal read cycle time	9 ms for 8 channels
Measurement error	<= 0.2 % of full scale +/- 10 V 0...60 °C 0.08 % of full scale +/- 5 V 25 °C 0.08 % of full scale 1...5 V 25 °C 0.08 % of full scale 0...5 V 25 °C 0.08 % of full scale 0...10 V 25 °C 0.08 % of full scale +/- 10 V 25 °C 0.15 % of full scale 4...20 mA 25 °C 0.15 % of full scale 0...20 mA 25 °C 0.15 % of full scale +/- 20 mA 25 °C <= 0.3 % of full scale 4...20 mA 0...60 °C <= 0.3 % of full scale 0...20 mA 0...60 °C <= 0.3 % of full scale +/- 20 mA 0...60 °C <= 0.1 % of full scale 1...5 V 0...60 °C <= 0.1 % of full scale 0...5 V 0...60 °C <= 0.1 % of full scale 0...10 V 0...60 °C <= 0.1 % of full scale +/- 5 V 0...60 °C <= 0.1 % of full scale +/- 10 V 0...60 °C
Temperature drift	50 ppm/°C 30 ppm/°C
Recalibration	Factory calibrated
Common mode between channels	>= 120 dB
Digital value format	+/- 10000 by default +/- 32000 in user scale

The information provided in this documentation contains general descriptions and/or technical characteristics of the performance of the products contained herein. This documentation is not intended as a substitute for and is not to be used for determining suitability or reliability of these products for specific user applications. It is the duty of any such user or integrator to perform the appropriate and complete risk analysis, evaluation and testing of the products with respect to the relevant specific application or use thereof. Neither Schneider Electric Industries SAS nor any of its affiliates or subsidiaries shall be responsible or liable for misuse of the information contained herein.

Isolation voltage	50 V DC between channels 1400 V DC between channels and bus 1400 V DC between channels and ground
Measurement resolution	1.4 μ A 4...20 mA 1.4 μ A 0...20 mA 1.4 μ A +/- 20 mA 0.36 mV +/- 5 V 0.36 mV 1...5 V 0.36 mV 0...5 V 0.36 mV 0...10 V 0.36 mV +/- 10 V
Maximum conversion value	0...30 mA +/- 5 V 0...30 mA 4...20 mA 0...30 mA 0...20 mA 0...30 mA +/- 20 mA +/- 11.4 V 1...5 V +/- 11.4 V 0...5 V +/- 11.4 V 0...10 V +/- 11.4 V +/- 10 V
Status LED	1 LED red I/O 1 LED red ERR 1 LED per channel green channel diagnostic 1 LED green RUN
Product weight	0.165 kg
Current consumption	30 mA at 24 V DC 150 mA at 3.3 V DC

Environment

Ambient air temperature for operation	0...60 °C
Relative humidity	10...95 % without condensation
IP degree of protection	IP20
Protective treatment	TC

Offer Sustainability

Sustainable offer status	Not Green Premium product
RoHS (date code: YYWW)	Compliant - since 0901 - Schneider Electric declaration of conformity
REACH	Reference not containing SVHC above the threshold
Product environmental profile	Available Download Product Environmental

Modules Mounted on Racks

Dimensions

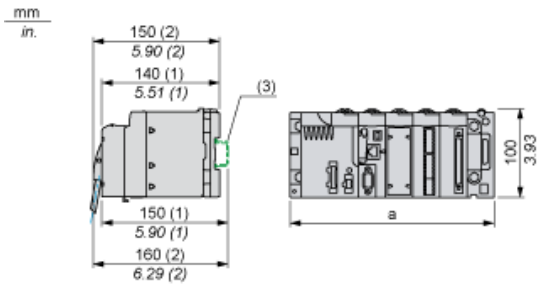

- (1) With removable terminal block (cage, screw or spring).
- (2) With FCN connector.
- (3) On AM1 ED rail: 35 mm wide, 15 mm deep. Only possible with BMXXBP0400/0400H/0600/0600H/0800/0800H rack.

Rack references	a in mm	a in in.
BMXXBP0400 and BMXXBP0400H	242.4	09.54
BMXXBP0600 and BMXXBP0600H	307.6	12.11
BMXXBP0800 and BMXXBP0800H	372.8	14.68
BMXXBP1200 and BMXXBP1200H	503.2	19.81

Wiring Diagram

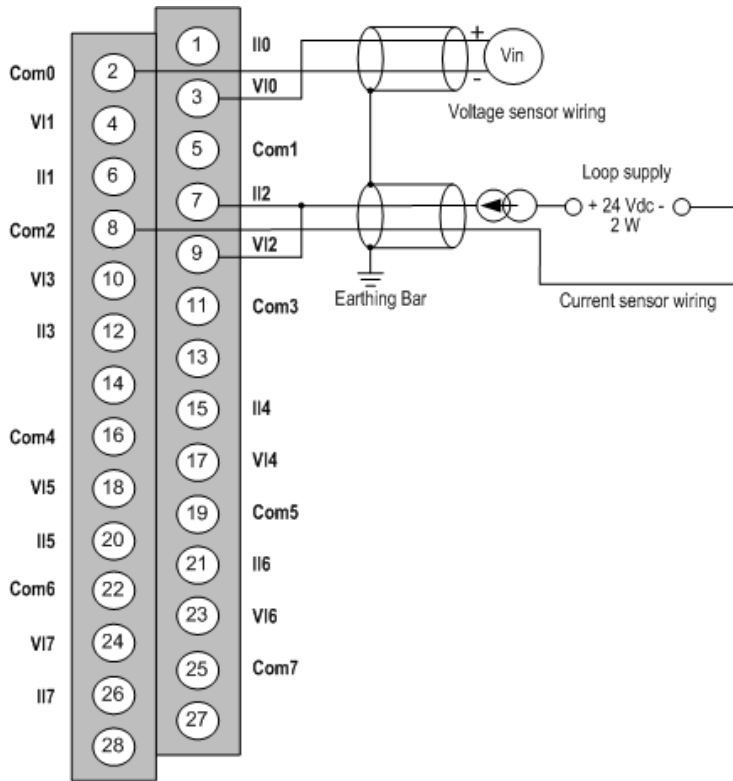

V1x + pole input for channel x.
 COMx pole input for channel x, COMx are connected together internally.
 I1x current reading resistor + input.
 Channel voltage sensor.
 0
 Channel wire current sensor.
 1