

## Main

Range of product	Modicon Premium Automation platform
Product or component type	Measurement and counter module
I/O modularity	2 channels
Electrical circuit type	Auxiliary output conforming to EN/IEC 61131-2

## Complementary

Counting frequency	1000000 Hz
Incremental encoder frequency x1	500 kHz
Incremental encoder frequency x 4	250 kHz
Power dissipation in W	7...10 W
Module cycle time	1
Discrete input logic	Resistive encoder input Resistive 2/3-wire proximity sensors PNP/NPN conforming to IEC 1131 Type 2 Current sink auxiliary input (preset, enable and read) conforming to IEC 1131 Type 2
Input logic	Positive
Input compatibility	Absolute encoder parallel output ABE7CPA11 Incremental encoder 5 V DC RS422 Incremental encoder 10...30 V totem pole Absolute encoder SSI serial output
Input voltage	5 V 18 mA encoder input 24 V 8 mA auxiliary input (preset, enable and read) 24 V 16 mA 2/3-wire proximity sensors PNP/NPN
Input voltage limits	19...30 V auxiliary input (preset, enable and read) 19...30 V 2/3-wire proximity sensors PNP/NPN <= 5.5 V encoder input
Voltage state1 guaranteed	>= 2.4 V encoder input >= 11 V auxiliary input (preset, enable and read) >= 11 V 2/3-wire proximity sensors PNP/NPN
Current state 1 guaranteed	> 6 mA auxiliary input (preset, enable and read) > 6 mA 2/3-wire proximity sensors PNP/NPN > 3.6 mA encoder input
Voltage state 0 guaranteed	<= 5 V auxiliary input (preset, enable and read) <= 5 V 2/3-wire proximity sensors PNP/NPN <= 1.2 V encoder input
Current state 0 guaranteed	< 2 mA auxiliary input (preset, enable and read) < 2 mA 2/3-wire proximity sensors PNP/NPN < 1 mA encoder input
Response time	< 2.5 ms sensor voltage at loss of 24 V auxiliary input (preset, enable and read) < 10 ms sensor voltage at return of 24 V auxiliary input (preset, enable and read)
Input impedance	400 Ohm at Un encoder input 3400 Ohm at Un auxiliary input (preset, enable and read) 1500 Ohm at Un 2/3-wire proximity sensors PNP/NPN > 270 Ohm at U = 2.4 V encoder input
Output voltage	24 V DC
Nominal output current	0.5 A
Output voltage limits	19...30 V

Voltage drop	< 0.5 V at state 1
Output compatibility	Positive logic DC inputs (resistance <= 15 kOhm) auxiliary output
Leakage current	< 0.1 mA
Switching time	< 250 ms
Switching frequency	< 0.6/LI <sup>2</sup> Hz on inductive load
Output overload protection	Thermal tripping via program or automatically Current limiter
Output short-circuit protection	Thermal tripping via program or automatically Current limiter
Output overvoltage protection	Zener diode
Reverse polarity protection	Reverse diode on supply
Checks	Sensor power supply
Current consumption	850 mA 5 V DC 15 mA 24 V DC
Module format	Standard
Local signalling	2 LED green axis diagnostics available (CH.) 1 LED red internal fault, module failure (ERR) 1 LED red external fault (I/O) 1 LED green module operating (RUN)
Electrical connection	2 connectors SUB-D 15 1 connector HE-10 20 pins
Product weight	0.34 kg

## Environment

Protective treatment	TC
Ambient air temperature for operation	0...60 °C
Ambient air temperature for storage	-25...70 °C
Relative humidity	5...95 % without condensation
Operating altitude	<= 2000 m

## Offer Sustainability

Sustainable offer status	Not Green Premium product
RoHS	Compliant - since 0804 - Schneider Electric declaration of conformity <a href="#">download declaration of conformity</a>

## Standard and Extendable Racks for Modules Mounting

### Dimensions of Modules and Racks



(1) With screw terminal block modules.

(2) Maximum depth for all types of modules and their associated connectors.

15-pin SUB-D Connectors of the Measurement and Counting Module

Pinout Configuration

Standard 15-pin SUB-D connector for connecting the counting sensor to channels 0, 1, 2 or 3

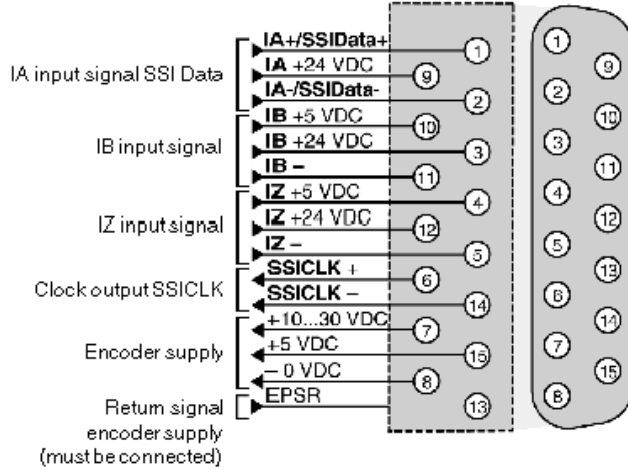

5 Vdc signal	Pins
+ IA input	1
- IA input	2
+ IB input	10
- IB input	11
+ IZ input	4
- IZ input	5
Encoder power supply:	
+5 Vdc	15
-0 Vdc	8
Encoder power supply feedback	13
10...30 Vdc signals	Pins
+ IA input	9
- IA input	2
+ IB input	3
- IB input	11
+ IZ input	12
- IZ input	5
Encoder power supply:	
+10...30 Vdc	7
-0 Vdc	8
Encoder power supply feedback	13
Serial signals (absolute encoder with serial or parallel outputs, using a TELEFAST ABE7CPA11 adapter)	Pins
+ SSI Data	1
- SSI Data	2
+ SSI CLK input	6

Serial signals (absolute encoder with serial or parallel outputs, using a TELEFAST ABE7CPA11 adapter)	Pins
- SSI CLK input	14
Encoder power supply:	
+5 Vdc	15
-0 Vdc	8
Encoder power supply feedback	13

## 20-pin HE10 Connector of the Measurement and Counting Module

### Wiring Diagram

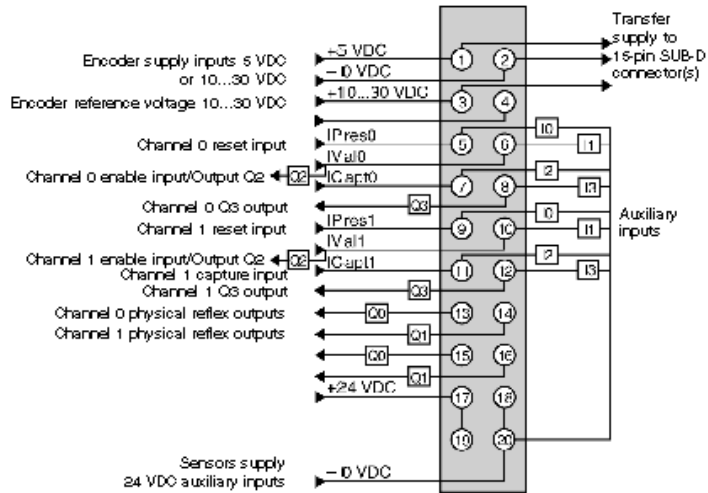

24 Vdc signals	Pins
Channel 0 auxiliary input:	
Preset IPres0	5
Confirmation IVal0/Output Q2	6
Capture ICapt0	7
Output Q3	8
Channel 1 auxiliary input:	
Preset IPres1	9
Confirmation IVal1/Output Q2	10
Capture ICapt1	11
Output Q3	12
Channel 0 reflex output:	
Output Q0	13
Output Q1	14
Channel 1 reflex output:	
Output Q0	15
Output Q1	16
Power Supplies	
Encoder power supply:	
+5 Vdc	1
- 0 Vdc	2
+10...30 Vdc	3
Encoder reference voltage +10...30 Vdc	4
Sensor power supply:	
+24 Vdc	17 or 19

Power Supplies	Pins
-0 Vdc	18 or 20