



### Main

Range of product	Modicon OTB
Product or component type	I/O distributed module
Integrated connection type	Non isolated serial link 2 x RJ45 in parallel, master/slave Modbus, RTU/ASCII, transmission mode: asynchronous in baseband, RS485, transmission mode: 2 twisted shielded pairs at 1.2...38.4 kbit/s half duplex
Discrete input number	12 conforming to EN/IEC 61131 type 1
Discrete input logic	Sink or source
Discrete input current	7 mA for I8...I11 7 mA for I2...I5 5 mA for I6...I7 5 mA for I0...I1
Discrete output number	6 relay for Q2...Q7 2 solid state PNP for Q0...Q1 output logic: source
Discrete output current	300 mA solid state 2000 mA relay

### Complementary

Topology	Devices linked by daisy-chaining or tap junctions
Bus length	0...10 m tap-off length: 0...15 m
Number of devices per segment	0...32
Data format	7 or 8 bits, 1 or 2 stop bits
Parity	Even No Odd
Discrete input voltage	24 V
Discrete input voltage type	DC
Discrete input type	NPN or PNP
Input voltage limits	20.4...26.4 V
Electronic filtering time	0.15 ms for I8...I11 at state 0 0.15 ms for I2...I5 at state 0 0.045 ms for I6...I7 at state 0 0.045 ms for I0...I1 at state 0 0.04 ms for I8...I11 at state 1 0.04 ms for I2...I5 at state 1 0.035 ms for I6...I7 at state 1 0.035 ms for I0...I1 at state 1
Configurable filtering time	0 ms 12 ms 3 ms
Input impedance	5.7 kOhm for I6...I7 5.7 kOhm for I0...I1 3.4 kOhm for I8...I11 3.4 kOhm for I2...I5
Discrete output voltage	30 V DC relay 240 V AC relay 24 V DC solid state
Output voltage limits	20.4...28.8 V solid state
Output current limits	360 mA solid state
Current per output common	<= 0.72 A solid state 8 A relay
Current consumption	5 mA at 5 V DC (at state 0) relay output 40 mA at 24 V DC (at state 1) relay output 30 mA at 5 V DC (at state 1) relay output

The information provided in this documentation contains general descriptions and/or technical characteristics of the performance of the products contained herein. This documentation is not intended as a substitute for and is not to be used for determining suitability or reliability of these products for specific user applications. It is the duty of any such user or integrator to perform the appropriate and complete risk analysis, evaluation and testing of the products with respect to the relevant specific application or use thereof. Neither Schneider Electric Industries SAS nor any of its affiliates or subsidiaries shall be responsible or liable for misuse of the information contained herein.

Output overvoltage protection	38...40 V
Tungsten load	8 W for solid state
Response time	5 $\mu$ s at state 1 for solid state 5 $\mu$ s at state 0 for solid state 300 $\mu$ s at state 1 for relay 300 $\mu$ s at state 0 for relay
Switchable load	$\geq$ 0.1 mA
Contact bounce time	$\leq$ 1 ms for relay
Leakage current	$\leq$ 0.1 mA at state 0 for solid state
Drop-out voltage	$\leq$ 1 V at state 1
Insulation between channels and internal logic	500 Vrms for 1 minute for solid state output 500 Vrms for 1 minute for input circuit 1500 Vrms for 1 minute for relay output
Insulation between channels	None
Contact resistance	$\leq$ 30 mOhm
Electrical durability	500000 cycles DC-13 with 30 W load for relay output 500000 cycles DC-1 with 60 W load for relay output 500000 cycles AC-15 with 200 VA load for relay output 500000 cycles AC-14 with 250 VA load for relay output 500000 cycles AC-1 with 500 VA load for relay output
Supply circuit type	DC
[Us] rated supply voltage	24 V
Supply voltage limits	20.4...26.2 V
Input current	$\leq$ 700 mA at 26.2 V for supply circuit
Inrush current	$\leq$ 50 A for supply circuit $\leq$ 1 A for solid state output
Power consumption	19 W
Number of I/O expansion module	0...7
I/O expansion capacity	7 x 8I or 7 x 2I or 7 x (4I/2O) with screw terminal analogue I/O module(s) 244 with HE10 connector discrete I/O module(s) 188 with spring terminal discrete I/O module(s) 132 with screw terminal discrete I/O module(s)
Insulation resistance	$\geq$ 10 mOhm between power supply and earth $\geq$ 10 mOhm between I/O and earth terminals
I/O connection	Removable screw terminal block
Number of common point	1 for solid state output 1 for relay output (3 NO) 1 for relay output (2 NO) 1 for relay output (1 NO) 1 for input
Counting input number	2
Counting capacity	32 bits
Counting frequency	20000 Hz 5000 Hz
Pulse generator number	2
Pulse generator frequency	7 kHz
Pulse generator function	RPLS pulse generator output RPWM pulse width modulation
Marking	CE
Fixing mode	By screws on solid plate with fixing kit By screws on panel with fixing kit By clips on 35 mm symmetrical DIN rail
Status LED	1 LED, yellow for COM 1 LED, red for ERR 1 LED, green for PWR 1 LED per channel, green for I/O
Product weight	0.19 kg

## Environment

IP degree of protection	IP20
Immunity to microbreaks	10 ms for supply circuit
Dielectric strength	500 V between power supply and earth 500 V between I/O and earth terminals
Standards	CSA EN 61131-2 IEC 61131-2 UL 508 CSA C22.2 No 213 Class I Division 2 Group A CSA C22.2 No 213 Class I Division 2 Group B CSA C22.2 No 213 Class I Division 2 Group C CSA C22.2 No 213 Class I Division 2 Group D
Product certifications	CULus
Ambient air temperature for operation	0...55 °C
Ambient air temperature for storage	-25...70 °C
Relative humidity	30...95 % without condensation
Pollution degree	2 conforming to IEC 60664 2 conforming to EN 60664
Operating altitude	0...2000 m
Storage altitude	0...3000 m
Vibration resistance	1 gn (f = 57...150 Hz) on 35 mm symmetrical DIN rail 0.075 mm (f = 10...57 Hz) on 35 mm symmetrical DIN rail
Shock resistance	15 gn for 11 ms conforming to IEC 61131 15 gn for 11 ms conforming to EN 61131
Resistance to electrostatic discharge	4 kV in contact conforming to EN 61000-4-2 8 kV in air conforming to IEC 61000-4-2 8 kV in air conforming to EN 61000-4-2 4 kV in contact conforming to IEC 61000-4-2
Resistance to radiated fields	10 V/m, 80000000...2000000000 Hz conforming to IEC 61000-4-3 10 V/m, 80000000...2000000000 Hz conforming to EN 61000-4-3
Resistance to fast transients	2 kV for 24 V supply conforming to IEC 61000-4-4 1 kV for 24 V solid state I/O conforming to IEC 61000-4-4

Network Interface Module

Dimensions

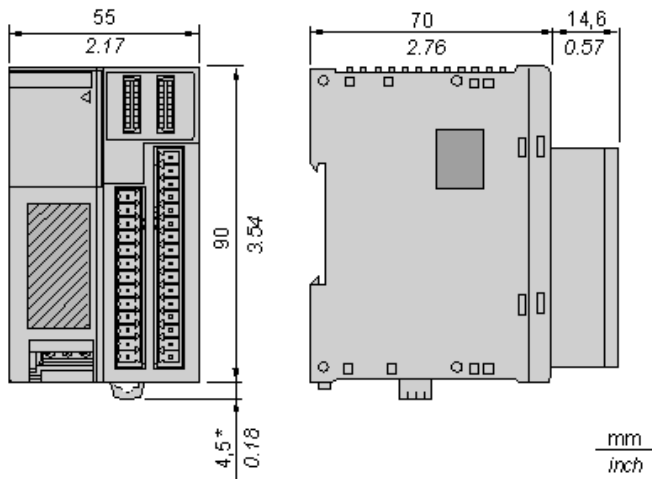

NOTE: \* 8.5 mm (0.33 in) when the clamp is pulled out.

---

Mounting an Island on a Panel or in a Cabinet

---

Spacing Requirements

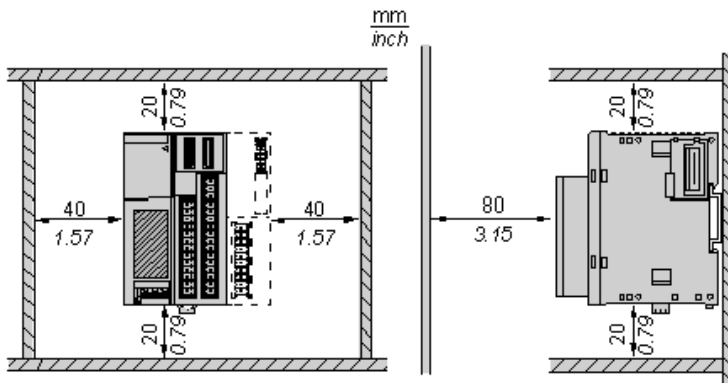

---

Panel Mounting

---

Position of the Mounting Holes for the Network Interface Module

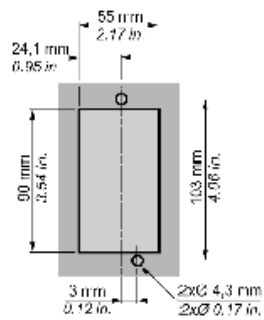

24 Vdc Power Supply

Wiring Diagram

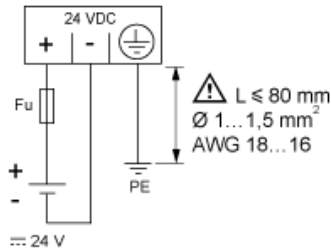

Fu 2 A fast-blow fuse ABE7FU200

Network Interface Module

Wiring Diagram

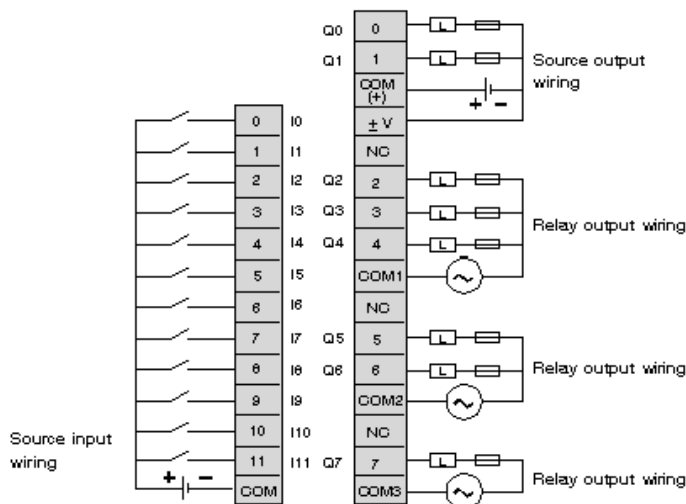

- Output points 0 and 1 are source transistor outputs, all other output points are relay.
- The COM terminals are not connected together internally.
- Connect an appropriate fuse for the load.