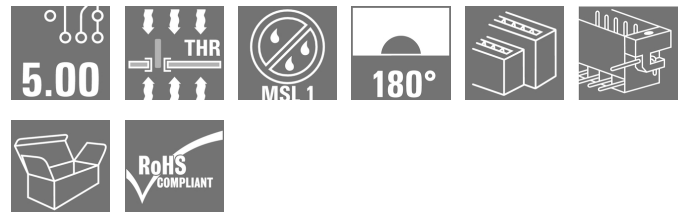

**SLDV-THR 5.00/08/180GLF 3.2SN BK BX**

**Weidmüller Interface GmbH & Co. KG**  
 Klingenbergstraße 26  
 D-32758 Detmold  
 Germany

www.weidmueller.com

**Product image**

Similar to illustration

High-temperature resistant, double level, laterally offset, closed ended male header, with solder flange option. 1.5 mm solder pin suitable for reflow soldering. 3.2 mm solder pin suitable for reflow and wave soldering. The pin headers provide space for labelling and can be coded.

**General ordering data**

Version	PCB plug-in connector, male header, closed side / solder flange, THT/THR solder connection, 5.00 mm, Number of poles: 8, 180°, Solder pin length (l): 3.2 mm, tinned, black, Box
Order No.	<a href="#">1911320000</a>
Type	SLDV-THR 5.00/08/180GLF 3.2SN BK BX
GTIN (EAN)	4032248539413
Qty.	50 pc(s).
Product data	IEC: 400 V / 15 A UL: 300 V / 10 A
Packaging	Box

Creation date March 26, 2021 7:27:51 AM CET

## SLDV-THR 5.00/08/180GLF 3.2SN BK BX

Weidmüller Interface GmbH &amp; Co. KG

Klingenbergstraße 26

D-32758 Detmold

Germany

www.weidmueller.com

## Technical data

## Dimensions and weights

Depth	23.43 mm	Depth (inches)	0.922 inch
Height	29.36 mm	Height (inches)	1.156 inch
Height of lowest version	26.16 mm	Net weight	7.86 g
Width	23 mm	Width (inches)	0.906 inch

## System specifications

Product family	OMNIMATE Signal - series BL/SL 5.00	Type of connection	Board connection
Mounting onto the PCB	THT/THR solder connection	Pitch in mm (P)	5 mm
Pitch in inches (P)	0.197 inch	Outgoing elbow	180°
Number of poles	8	Number of solder pins per pole	1
Solder pin length (l)	3.2 mm	Solder pin length tolerance	+0.1 / -0.2 mm
Solder pin dimensions	d = 1.2 mm, Octagonal	Solder pin dimensions = d tolerance	0 / -0,03 mm
Solder eyelet hole diameter (D)	1.5 mm	Solder eyelet hole diameter tolerance (D)	+ 0,1 mm
L1 in mm	15 mm	L1 in inches	0.591 inch
Number of rows	2	Pin series quantity	2
Touch-safe protection acc. to DIN VDE 57 106	finger-safe plugged/ back-of-hand-safe unplugged	Touch-safe protection acc. to DIN VDE 0470	IP20 plugged/ IP10 unplugged
Volume resistance	≤5 mΩ	Can be coded	Yes
Plugging force/pole, max.	9 N	Pulling force/pole, max.	8 N

## Material data

Insulating material	LCP GF	Colour	black
Colour chart (similar)	RAL 9011	Insulating material group	Illa
Comparative Tracking Index (CTI)	≥ 175	Moisture Level (MSL)	1
UL 94 flammability rating	V-0	Contact material	CuSn
Contact surface	tinned	Layer structure of solder connection	1...3 μm Ni / 2...4 μm Sn matt
Layer structure of plug contact	1...3 μm Ni / 2...4 μm Sn matt	Storage temperature, min.	-40 °C
Storage temperature, max.	70 °C	Operating temperature, min.	-50 °C
Operating temperature, max.	100 °C	Temperature range, installation, min.	-25 °C
Temperature range, installation, max.	100 °C		

## Rated data acc. to IEC

tested acc. to standard	IEC 60664-1, IEC 61984	Rated current, min. number of poles (Tu=20°C)	15 A
Rated current, max. number of poles (Tu=20°C)	10.5 A	Rated current, min. number of poles (Tu=40°C)	13 A
Rated current, max. number of poles (Tu=40°C)	9 A	Rated voltage for surge voltage class / pollution degree II/2	400 V
Rated voltage for surge voltage class / pollution degree III/2	320 V	Rated voltage for surge voltage class / pollution degree III/3	250 V
Rated impulse voltage for surge voltage class/ pollution degree II/2	4 kV	Rated impulse voltage for surge voltage class/ pollution degree III/2	4 kV
Rated impulse voltage for surge voltage class/ contamination degree III/3	4 kV	Short-time withstand current resistance	1 x 1s with 120 A

## SLDV-THR 5.00/08/180GLF 3.2SN BK BX

Weidmüller Interface GmbH &amp; Co. KG

Klingenbergstraße 26

D-32758 Detmold

Germany

www.weidmueller.com

## Technical data

## Rated data acc. to CSA

Institute (CSA)



Certificate No. (CSA)

200039-1121690

Rated voltage (Use group B / CSA) 300 V

Rated voltage (Use group D / CSA) 300 V

Rated current (Use group B / CSA) 10 A

Rated current (Use group D / CSA) 10 A

Reference to approval values

Specifications are maximum values, details - see approval certificate.

## Rated data acc. to UL 1059

Institute (UR)



Certificate No. (UR)

E60693

Institute (cURus)



Certificate No. (cURus)

E60693

Rated voltage (Use group B / UL 1059) 300 V

Rated voltage (Use group D / UL 1059) 300 V

Rated current (Use group B / UL 1059) 10 A

Rated current (Use group D / UL 1059) 10 A

Reference to approval values

Specifications are maximum values, details - see approval certificate.

## Packing

Packaging	Box	VPE length	60 mm
VPE width	100 mm	VPE height	250 mm

## Classifications

ETIM 6.0	EC002637	ETIM 7.0	EC002637
ECLASS 9.0	27-44-04-02	ECLASS 9.1	27-44-04-02
ECLASS 10.0	27-44-04-02	ECLASS 11.0	27-46-02-01

## Important note

IPC conformity

Conformity: The products are developed, manufactured and delivered according international recognized standards and norms and comply with the assured properties in the data sheet resp. fulfill decorative properties in accordance with IPC-A-610 "Class 2". Further claims on the products can be evaluated on request.

Notes

- Rated current related to rated cross-section & min. No. of poles.
- Spacing between rows: see hole layout
- P on drawing = pitch
- Rated data refer only to the component itself. Clearance and creepage distances to other components are to be designed in accordance with the relevant application standards.
- Long term storage of the product with average temperature of 50 °C and average humidity 70%, 36 months

**Data sheet****SLDV-THR 5.00/08/180GLF 3.2SN BK BX****Weidmüller Interface GmbH & Co. KG**  
Klingenbergstraße 26  
D-32758 Detmold  
Germany

www.weidmueller.com

**Technical data****Approvals**

Approvals



ROHS	Conform
UL File Number Search	E60693

**Downloads**

Approval/Certificate/Document of Conformity	<a href="#">Declaration of the Manufacturer</a>
Engineering Data	<a href="#">STEP</a>

**SLDV-THR 5.00/08/180GLF 3.2SN BK BX**

**Weidmüller Interface GmbH & Co. KG**  
 Klingenbergstraße 26  
 D-32758 Detmold  
 Germany

www.weidmueller.com

**Dimensional drawing**

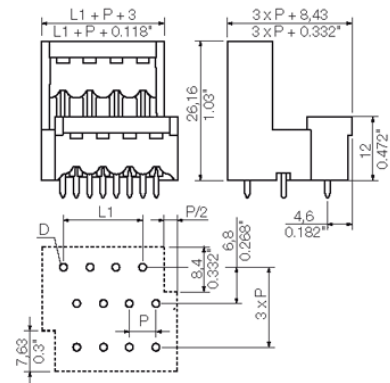

**Product benefits**

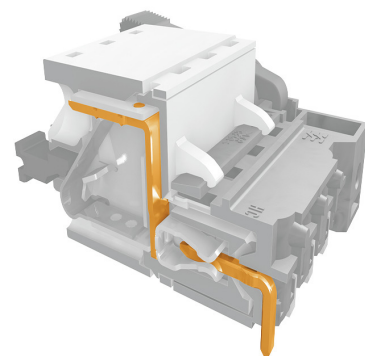

Safe power transmission  
 Proven properties

**Data sheet**

**SLDV-THR 5.00/08/180GLF 3.2SN BK BX**

**Weidmüller Interface GmbH & Co. KG**  
Klingenbergstraße 26  
D-32758 Detmold  
Germany

[www.weidmueller.com](http://www.weidmueller.com)

**Drawings**

**Product benefits**



Compliant with existing standards

MASSE OHNE TOLERANZ SIND KEINE PRUEFMASSE  
DIMS. WITHOUT TOLERANCE ARE NOT CONTROL DIMS.

DIE DEUTSCHE VERSION IST VERBINDLICH  
THE GERMAN VERSION IS BINDING

**Technical Data**

Rev.

**Material data**

Insulation material type	LCP GF
Insulation material colours	black
Insulation material flammability class	UL94 V-0
Insulation resistance	10 <sup>5</sup> MOhm
Contact base material	CuSn
Contact plating (mating end)	tin plated
Contact plating (solder end)	tin plated

**System characteristic values**

together with counterpart

Pitch <b>P</b>	mm/inch	5.00/0.197
Number of rows		2
Dielectric strength (r.m.s withstand voltage)	kV	4
Mechanical operating cycles	acc. to IEC 512	25
Plug in force (max.)	N/pole	n.a.
Pull out force (max.)	N/pole	n.a.
Through resistance (typical)	mOhm	<5
Operating temperature range	°C	-55...+100
Degree of protection acc. to VDE 0106 (plugged/unplugged)		back of hands
Degree of protection acc. to DIN EN 60529 (plugged/unplugged)		IP10
Solder pin length <b>L</b>	mm/inch	3.2/0.126 ; 1.5/0.059
PCB hole diameter <b>D</b> (wave soldering)	mm/inch	1.4/0.055
PCB hole diameter <b>D</b> (reflow soldering)	mm/inch	1.5/0.059
Resistance to soldering heat acc. to DIN IEC 60512-6	°C/sec	260/5
Resistance to soldering heat acc. to EN 61760-1	°C/sec	290/30
Solderability classification acc. to EN 61760-1		class A
Solder connection type		through hole solder
Solder pin diameter <b>d</b> (max.)	mm/inch	1.2/0.047

**Application notes**

Coding possibility	yes/no	yes
Joinable without loss of pitch	yes/no	n.a.
Manual assembly of modules	yes/no	n.a.
Max. number of poles	n	48

**IEC 664-1 / VDE0110 (4.97) rated data**

Rated cross section acc. to EN 60999	mm <sup>2</sup>	n.a.
Rated current @ 20°C ambient (together with)	A	18.6
Rated current @ 40°C ambient (together with)	A	16.1
<b>Overvoltage category / Pollution degree</b>	III/3 III/2 II/2	
Rated voltage	V	250 320 400
Rated impulse voltage	kV	4.0 4.0 4.0

**UL 1059 rated data**

File No.: E60693

Rated voltage	V	300	300
Rated current	A	10	10
AWG wire range (field wiring / factory wiring)		n.a.	

**CSA C22.2 rated data**

File No.: 12400 (old)  
ReportNo.: 1308147 (new)

Rated voltage	V	300	300
Rated current	A	10	10
AWG wire range (field wiring / factory wiring)		n.a.	

**Packaging**

carton

**Downloads**

www.weidmueller.de

- 1) Sum of ambient temperature and temperature rise
- 2) Recommendation for manual assembly
- 3) Recommendation for automatic assembly
- 4) Recommendation for wave soldering
- 5) Recommendation for reflow soldering
- 6) Referred to rated cross section and minimum pole number
- 7) Fingersafe above PC-board, if plugged with BLZ
- 8) IP20 above PC-board, if plugged with BLZ

n.a. = not applicable

Subject to technical changes

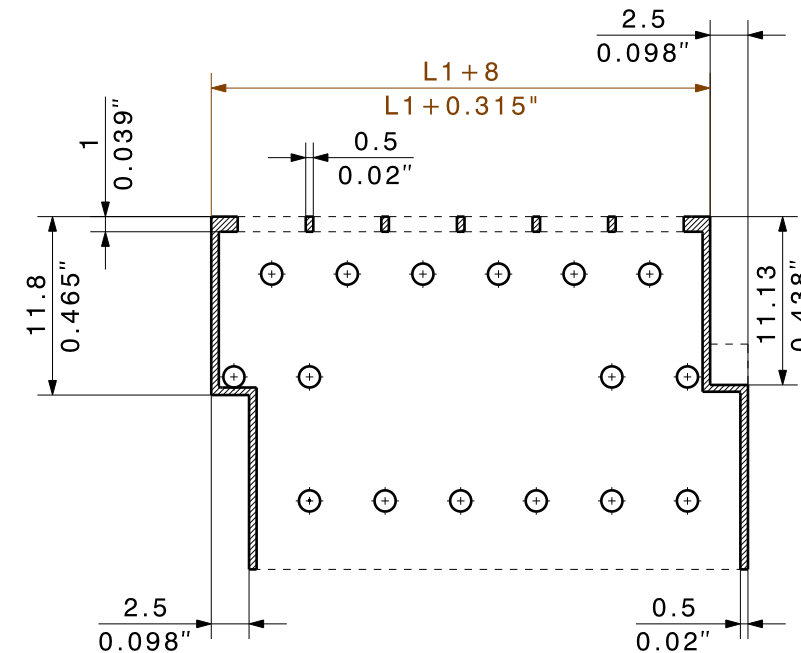
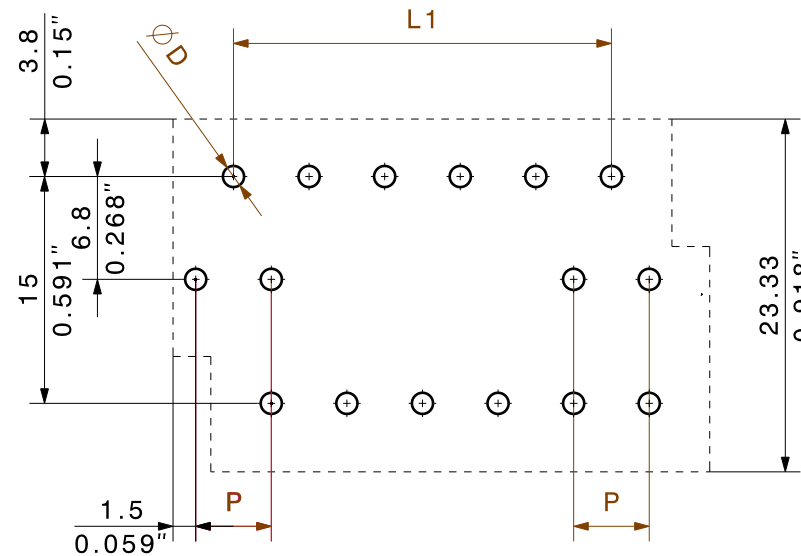
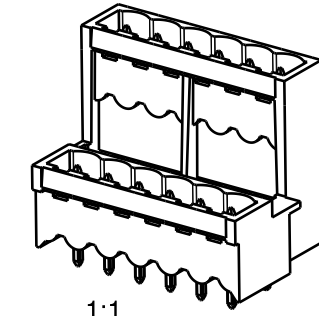
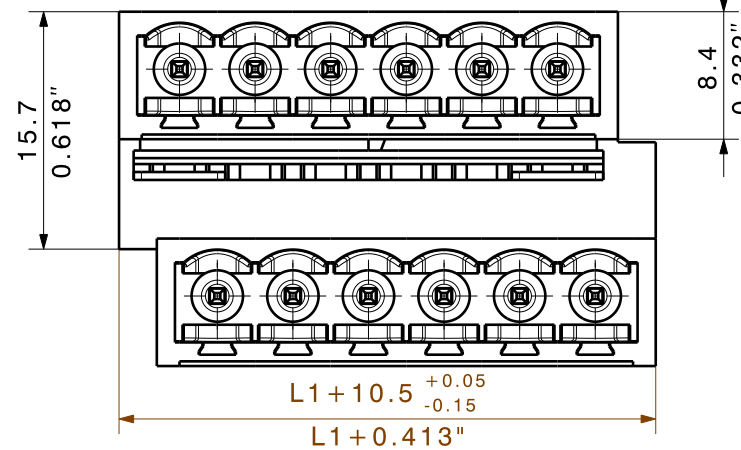
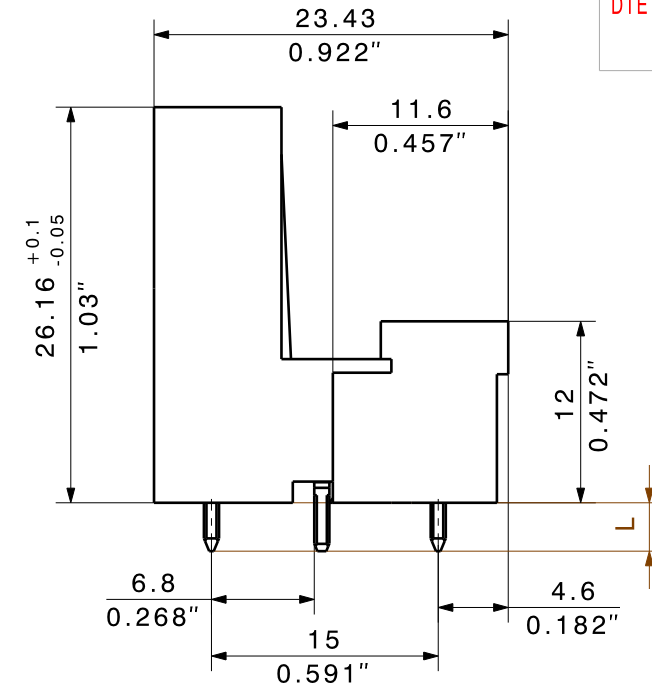
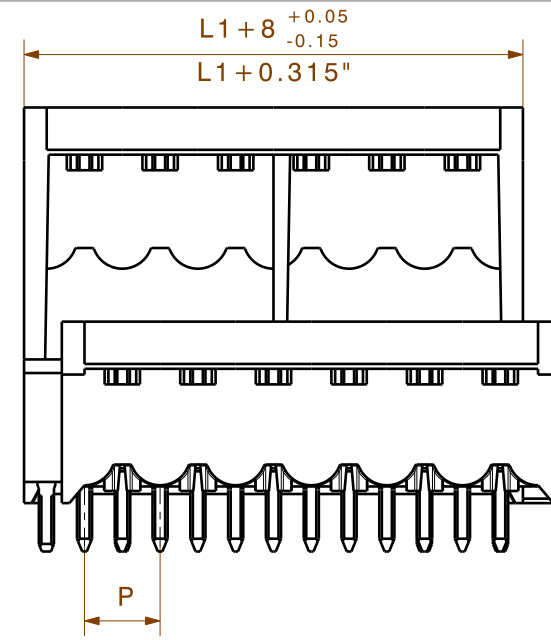

48	115,00	4,53
46	110,00	4,33
44	105,00	4,13
42	100,00	3,94
40	95,00	3,74
38	90,00	3,54
36	85,00	3,35
34	80,00	3,15
32	75,00	2,95
30	70,00	2,76
28	65,00	2,56
26	60,00	2,36
24	55,00	2,17
22	50,00	1,97
20	45,00	1,77
18	40,00	1,57
16	35,00	1,38
14	30,00	1,18
12	25,00	0,98
10	20,00	0,79
8	15,00	0,59
6	10,00	0,39
4	5,00	0,20
<b>n</b>	<b>L1 [mm]</b>	<b>L1 [inch]</b>

RoHS

37601/5  
07.09.07 HERTEL\_S 01  
MODIFICATION

**Weidmüller**

CAT.NO.:

**C 36146 05**

DRAWING NO. SHEET 5 OF 6 ISSUE NO. SHEETS



DRAWN	04.08.2004	HERTEL_S
RESPONSIBLE		HERTEL_S
CHECKED	13.09.2007	HERTEL_S
APPROVED		GUENTHER_W

**SLDV-THR 5.00/./180GLF**

SMT Doppelstock-Stiftleiste  
SMT double level pin header

SCALE: 2:1

SUPERSEDES: .

SUPERSEDED BY: .

PRODUCT FILE: SLDV-THR 5.08

None

WEITERGABE SOWIE VERVIELFÄLTIGUNG DIESER DOKUMENTS, VERWERTUNG UND MITTEILUNG SEINER INHALTS SIND VERBOTEN, SOWEIT NICHT AUSDRUECKLICH GESTATET. ZUWIDERHANDLUNGEN VERPFLICHTEN ZU SCHADENSERSATZ. ALLE RECHTE FUER DEN FALL DER PATENT-, GEBRAUCHSMUSTER- ODER GESCHMACKSMUSTERREINTRAGUNG VORBEHALTEN. THE REPRODUCTION, DISTRIBUTION AND UTILIZATION OF THIS DOCUMENT AS WELL AS THE COMMUNICATION OF ITS CONTENTS TO OTHERS WITHOUT EXPLICIT AUTHORIZATION IS PROHIBITED. OFFENDERS WILL BE HELD LIABLE FOR THE PAYMENT OF DAMAGES. ALL RIGHTS RESERVED IN THE EVENT OF A PATENT, UTILITY MODEL OR DESIGN.

## Recommended wave soldering profiles

**Weidmüller Interface GmbH & Co. KG**  
 Klingenbergstraße 16  
 D-32758 Detmold  
 Germany  
 Fon: +49 5231 14-0  
 Fax: +49 5231 14-292083  
 www.weidmueller.com

### Single Wave:



### Double Wave:



### Wave soldering profiles

Wired connection elements should be processed in accordance with the DIN EN 61760-1 standard. We have included two recommendations for practical wave soldering profiles, with which Weidmüller PCB terminals and connectors are qualified.

When choosing a suitable profile for your application, the following factors also need to be considered:

- PCB thickness
- Proportion of Cu in the layers
- Single/double-sided assembly
- Product range
- Heating and cooling rates

The single and double wave profiles each indicate the recommended operating range, including the maximum soldering temperature of 260°C. In practice, the maximum soldering temperature is quite often well below the above maximum profile.

## Recommended reflow soldering profile

**Weidmüller Interface GmbH & Co. KG**  
 Klingenbergstraße 16  
 D-32758 Detmold  
 Germany  
 Fon: +49 5231 14-0  
 Fax: +49 5231 14-292083  
 www.weidmueller.com



### Reflow soldering profile

The perfect soldering profile for SMT Surface Mount Technology is one the most exiting question in SMT production. But there are more than one correct answer: The diagram of temperature-on-time is related to processing features of solder paste and to maximum load of components.

We have to consider the following parameters:

- Time for pre heating
- Maximum temperature
- Time above melting point
- Time for cooling
- Maximum heating rate
- Maximum cooling rate

We recommend a typical solder profile with associated process limits. With preheating components and board are prepared smoothly for the solder phase. Heating rate is typically  $\leq +3\text{K/s}$ . In parallel the solder paste is ‚activated‘. The time above melting point of 217°C the paste gets liquid and components and boards begin to connect. The maximum temperature of 245°C to 254°C should stay between 10 and 40 seconds. In the cooling phase at  $\geq -6\text{K/s}$  solder is cured. Board and components cool down while avoiding cold cracks.