



### Main

Range of product	Modicon TM7
Product or component type	Analog I/O expansion block
Range compatibility	Modicon LMC058 Modicon M258
Enclosure material	Plastic
Bus type	TM7 bus
[Ue] rated operational voltage	24 V DC
Input/Output number	4
Input/Output number of block	4 I

### Complementary

Analogue input number	4
Analogue input type	Voltage
Analogue input range	+/- 10 V
Analogue input resolution	11 bits + sign
Sensor power supply	24 V, 500 mA for all channels with overload, short-circuit and reverse polarity protection
Electrical connection	1 female connector M8 - 4 ways for power OUT 1 male connector M8 - 4 ways for power IN 4 female connectors M12 - A coding - 5 ways for sensor 1 female connector M12 - B coding - 4 ways for bus OUT 1 male connector M12 - B coding - 4 ways for bus IN
Local signalling	2 LEDs for sensor/actuator power supply status 2 LEDs for bus diagnostic
Operating position	Any position
Fixing mode	By 2 screws
Product weight	0.2 kg

### Environment

Standards	IEC 61131-2
Product certifications	C-Tick CURus GOST-R ATEX II 3g EEx nA II T5
Marking	CE
Ambient air temperature for operation	-10...60 °C
Ambient air temperature for storage	-25...85 °C
Relative humidity	5...95 % without condensation or dripping water
Pollution degree	2 conforming to IEC 60664
IP degree of protection	IP67 conforming to IEC 61131-2
Operating altitude	0...2000 m
Storage altitude	0...3000 m
Vibration resistance	4 gn constant acceleration (f = 200...500 Hz) conforming to IEC 60721-3-5 Class 5M3 2 gn constant acceleration (f = 8...200 Hz) conforming to IEC 60721-3-5 Class 5M3 7.5 mm constant amplitude (f = 2...8 Hz) conforming to IEC 60721-3-5 Class 5M3

Shock resistance	30 gn for 11 ms conforming to IEC 60721-3-5 Class 5M3
Resistance to electrostatic discharge	8 kV in air conforming to EN/IEC 61000-4-2 6 kV in contact conforming to EN/IEC 61000-4-2
Resistance to electromagnetic fields	1 V/m (f = 2...2.7 Hz conforming to EN/IEC 61000-4-3 10 V/m (f = 0.08...2 Hz conforming to EN/IEC 61000-4-3)
Resistance to fast transients	1 kV shielded cable conforming to EN/IEC 61000-4-4 1 kV input/output conforming to EN/IEC 61000-4-4 2 kV power supply conforming to EN/IEC 61000-4-4
Surge withstand for DC 24 V circuit	0.5 kV shielded links (differential mode) conforming to EN/IEC 61000-4-5 1 kV shielded links (common mode) conforming to EN/IEC 61000-4-5 0.5 kV unshielded links (differential mode) conforming to EN/IEC 61000-4-5 1 kV unshielded links (common mode) conforming to EN/IEC 61000-4-5 0.5 kV power supply (differential mode) conforming to EN/IEC 61000-4-5 1 kV power supply (common mode) conforming to EN/IEC 61000-4-5
Electromagnetic compatibility	EN/IEC 61000-4-6
Disturbance radiated/conducted	CISPR 11

## Offer Sustainability

Sustainable offer status	Green Premium product
RoHS (date code: YYWW)	Compliant - since 1039 - <a href="#">Schneider Electric declaration of conformity</a>
REACH	Reference not containing SVHC above the threshold
Product environmental profile	Available <a href="#">Download Product Environmental</a>
Product end of life instructions	Available <a href="#">Download End Of Life Manual</a>

Analog Input Block

Description

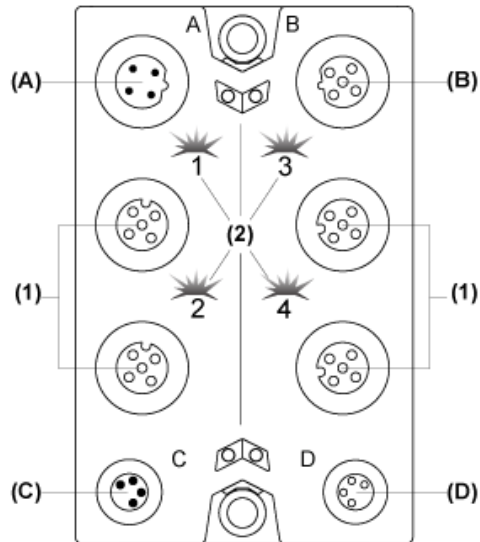

- (A) TM7 bus IN connector
- (B) TM7 bus OUT connector
- (C) 24 Vdc power IN connector
- (D) 24 Vdc power OUT connector
- (1) Input connectors
- (2) Status LEDs

Connector and Channel Assignments

Input connectors	Channel type	Channels
1	Input	I0
2	Input	I1
3	Input	I2
4	Input	I3

TM7 Block, Size 1

Dimensions

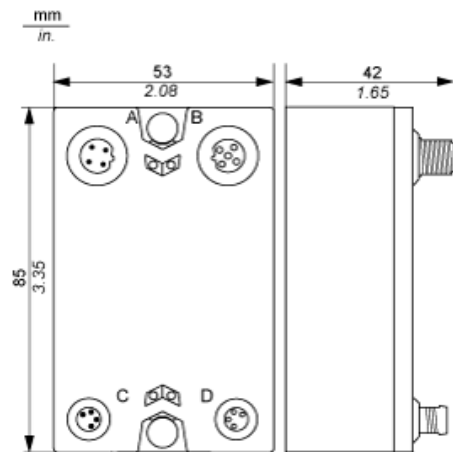

Spacing Requirements

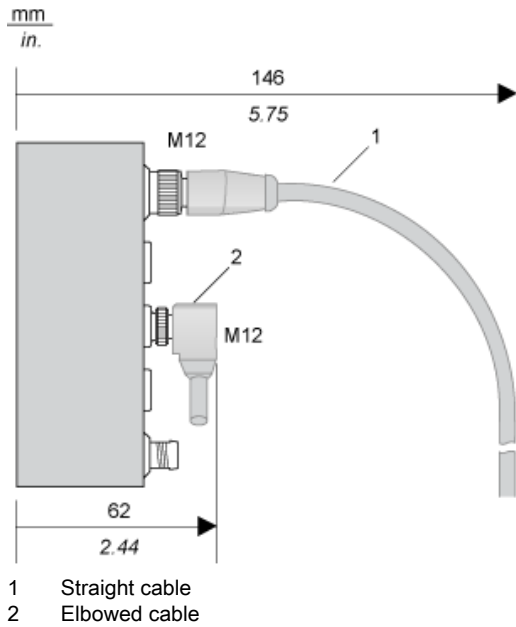

Installation Guidelines

TM7 Block on an Aluminium Frame

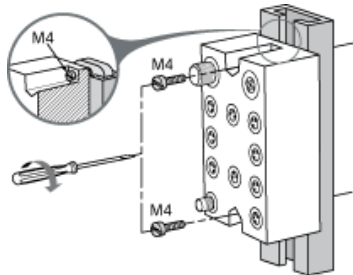

NOTE: Maximum torque to fasten the required M4 screws is 0.6 N.m (5.3 lbf-in).

TM7 Block on a DIN Rail

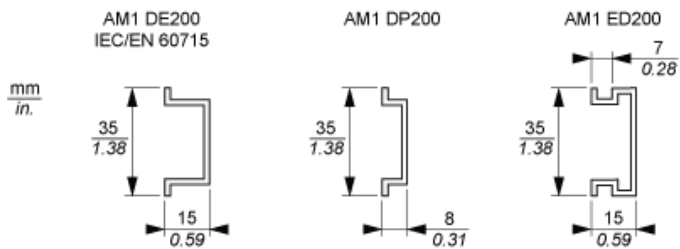

NOTE: Only size 1 (smallest) blocks can be installed on DIN rail with the TM7ACMP mounting plate.

## TM7 Block Directly on the Machine

Drilling template of the block:

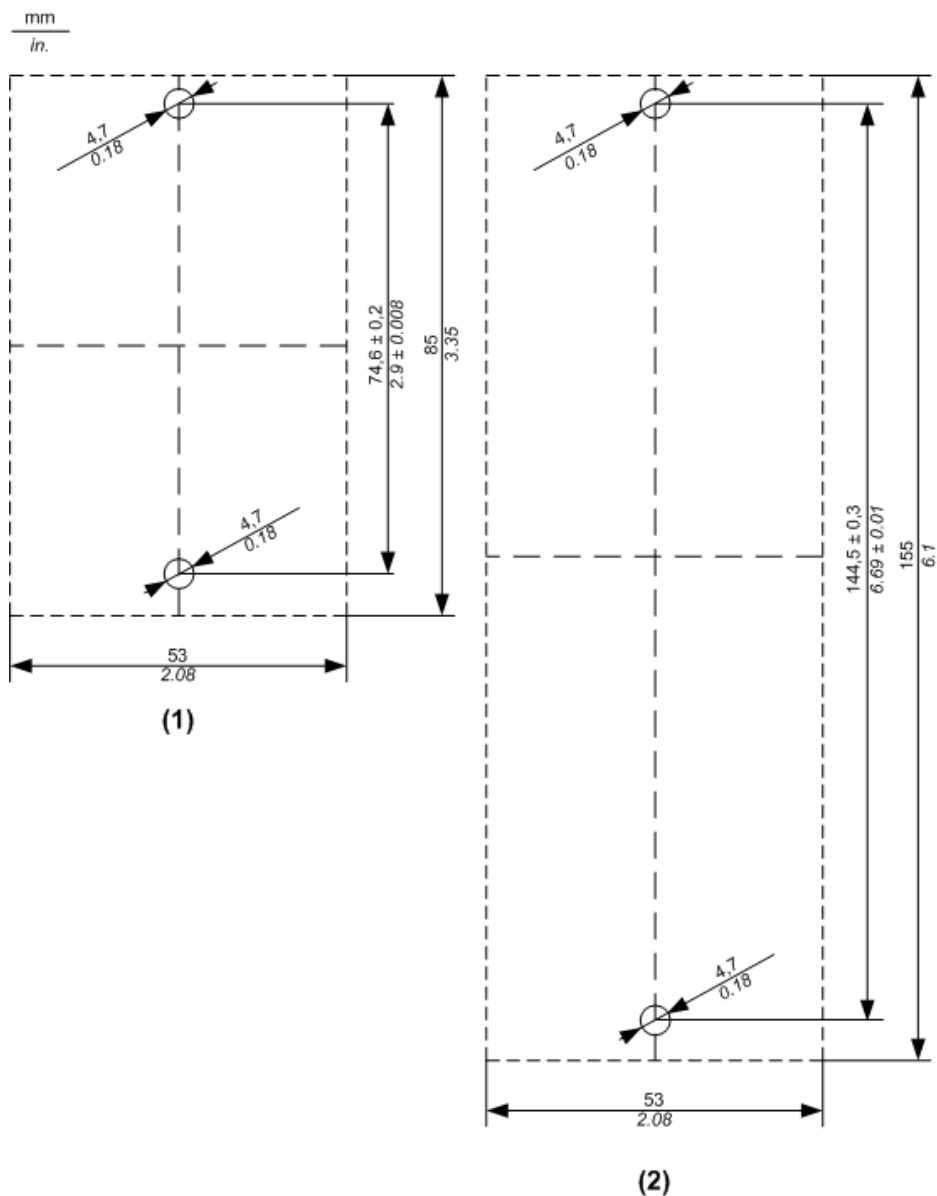

- (1) Size 1
- (2) Size 2

The thickness of the base plate should be taken into consideration when defining the screw length.

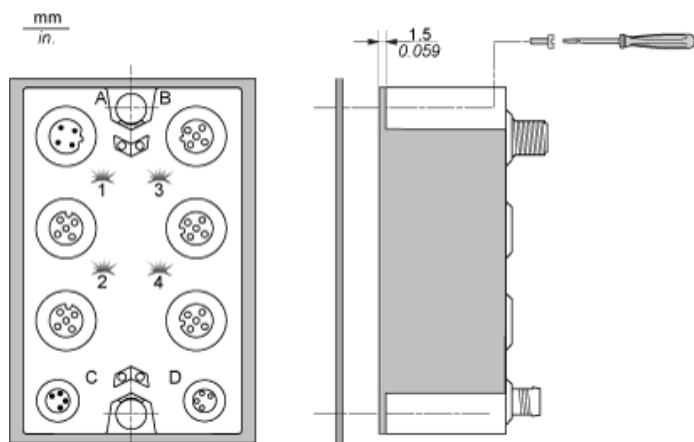

NOTE: Maximum torque to fasten the required M4 screws is 0.6 N.m (5.3 lbf-in).

Wiring Diagram

Pin Assignments for Input Connectors

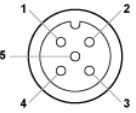
Connection	Pin	M12 input
	1	24 Vdc sensor supply
2	Analog input +	
3	0 Vdc	
4	Analog input -	
5	Shield	

Wiring the Power Supply

When you provide power to a TM7 I/O block using the 24 VDC Power OUT connector of the preceding I/O block, both blocks occupy the same 24 Vdc I/O power segment. However, if you connect an external isolated power supply to the 24 Vdc Power IN connector of a TM7 I/O block, you establish a new 24 Vdc I/O power segment beginning with that I/O block.

I/O block wired with one external 24 Vdc power supply:

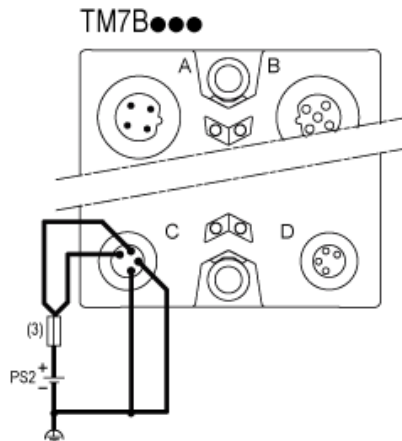

(3) External fuse, Type T slow-blow, 8 A max., 250 V

PS2 External isolated I/O power supply, 24 Vdc