

LLF 7.50/04/90V 5.0SN BK BX
Weidmüller Interface GmbH & Co. KG

Klingenbergstraße 26

D-32758 Detmold

Germany

www.weidmueller.com



The sturdy, direct connection for extreme current and voltage requirements in all power electronics applications such as solar inverters, frequency converters, servo-controllers and power supplies.

General ordering data

| | |
|--------------|--|
| Version | Printed circuit board terminals, 7.50 mm, Number of poles: 4, 90°, Solder pin length (l): 5 mm, tinned, black, PUSH IN with actuator, Clamping range, max. : 6 mm ² , Box |
| Order No. | 2472100000 |
| Type | LLF 7.50/04/90V 5.0SN BK BX |
| GTIN (EAN) | 4050118543780 |
| Qty. | 80 pc(s). |
| Product data | IEC: 1000 V / 41 A / 0.5 - 6 mm ² UL: 600 V / 35 A / AWG 24 - AWG 8 |
| Packaging | Box |

Creation date April 15, 2021 10:03:43 PM CEST

LLF 7.50/04/90V 5.0SN BK BX

Weidmüller Interface GmbH & Co. KG

Klingenbergstraße 26

D-32758 Detmold

Germany

www.weidmueller.com

Technical data

Dimensions and weights

| | | | |
|--------------------------|----------|-----------------|------------|
| Depth | 22.07 mm | Depth (inches) | 0.869 inch |
| Height | 36.55 mm | Height (inches) | 1.439 inch |
| Height of lowest version | 31.55 mm | Net weight | 14.715 g |
| Width | 31 mm | Width (inches) | 1.22 inch |

System parameters

| | | | |
|---|----------------------------|--|-----------------------|
| Product family | OMNIMATE Power - series LL | Wire connection method | PUSH IN with actuator |
| Mounting onto the PCB | THT solder connection | Conductor outlet direction | 90° |
| Pitch in mm (P) | 7.5 mm | Pitch in inches (P) | 0.295 inch |
| Number of poles | 4 | Pin series quantity | 1 |
| Fitted by customer | No | Solder pin length (l) | 5 mm |
| Solder pin dimensions | d = 1.5 mm | Solder eyelet hole diameter (D) | 2 mm |
| Solder eyelet hole diameter tolerance (D)+ 0,1 mm | | Number of solder pins per pole | 1 |
| Stripping length | 12 mm | L1 in mm | 22.5 mm |
| L1 in inches | 0.885 inch | Touch-safe protection acc. to DIN VDE 0470 | IP 20 |
| Touch-safe protection acc. to DIN VDE 57 106 | Safe from finger touch | | |

Material data

| | | | |
|-----------------------------|------------|--------------------------------------|------------------|
| Insulating material | Wemid (PA) | Colour | black |
| Colour chart (similar) | RAL 9011 | Insulating material group | I |
| UL 94 flammability rating | V-0 | Contact material | E-Cu |
| Contact surface | tinned | Layer structure of solder connection | 4...10 µ Sn matt |
| Storage temperature, min. | -40 °C | Storage temperature, max. | 70 °C |
| Operating temperature, min. | -40 °C | Operating temperature, max. | 120 °C |

Conductors suitable for connection

| | |
|---|----------------------|
| Clamping range, min. | 0.25 mm ² |
| Clamping range, max. | 6 mm ² |
| Wire connection cross section AWG, min. | AWG 24 |
| Wire connection cross section AWG, max. | AWG 8 |
| Solid, min. H05(07) V-U | 0.5 mm ² |
| Solid, max. H05(07) V-U | 6 mm ² |
| Flexible, min. H05(07) V-K | 0.5 mm ² |
| Flexible, max. H05(07) V-K | 6 mm ² |
| w. plastic collar ferrule, DIN 46228 pt 4, min. | 0.25 mm ² |
| w. plastic collar ferrule, DIN 46228 pt 4, max. | 6 mm ² |
| w. wire end ferrule, DIN 46228 pt 1, min. | 0.25 mm ² |
| w. wire end ferrule, DIN 46228 pt 1, max. | 6 mm ² |

LLF 7.50/04/90V 5.0SN BK BX

Weidmüller Interface GmbH & Co. KG
 Klingenbergstraße 26
 D-32758 Detmold
 Germany

www.weidmueller.com

Technical data

| | | | |
|--|--|------------------------------|-----------------------------|
| Clampable conductor | Cross-section for conductor connection | Type | fine-wired |
| | | nominal | 0.5 mm ² |
| wire end ferrule | | Stripping length | nominal 14 mm |
| | | Recommended wire-end ferrule | H0.5/18 OR |
| Cross-section for conductor connection | Type | fine-wired | |
| | nominal | 1 mm ² | |
| wire end ferrule | | Stripping length | nominal 15 mm |
| | | Recommended wire-end ferrule | H1.0/18 GE |
| Cross-section for conductor connection | Type | fine-wired | |
| | nominal | 1.5 mm ² | |
| wire end ferrule | | Stripping length | nominal 15 mm |
| | | Recommended wire-end ferrule | H1.5/18D SW |
| | | Stripping length | nominal 12 mm |
| | | Recommended wire-end ferrule | H1.5/12 |
| Cross-section for conductor connection | Type | fine-wired | |
| | nominal | 0.75 mm ² | |
| wire end ferrule | | Stripping length | nominal 14 mm |
| | | Recommended wire-end ferrule | H0.75/18 W |
| Cross-section for conductor connection | Type | fine-wired | |
| | nominal | 2.5 mm ² | |
| wire end ferrule | | Stripping length | nominal 14 mm |
| | | Recommended wire-end ferrule | H2.5/19D BL |
| | | Stripping length | nominal 12 mm |
| | | Recommended wire-end ferrule | H2.5/12 |
| Cross-section for conductor connection | Type | fine-wired | |
| | nominal | 4 mm ² | |
| wire end ferrule | | Stripping length | nominal 12 mm |
| | | Recommended wire-end ferrule | H4.0/12 |
| | | Stripping length | nominal 14 mm |
| | | Recommended wire-end ferrule | H4.0/20D GR |
| Cross-section for conductor connection | Type | fine-wired | |
| | nominal | 6 mm ² | |
| wire end ferrule | | Stripping length | nominal 14 mm |
| | | Recommended wire-end ferrule | H6.0/20 SW |
| | | Stripping length | nominal 12 mm |
| | | Recommended wire-end ferrule | H6.0/12 |
| Cross-section for conductor connection | Type | fine-wired | |
| | nominal | 10 mm ² | |
| wire end ferrule | | Stripping length | nominal 12 mm |
| | | Recommended wire-end ferrule | |

Reference text Length of ferrules is to be chosen depending on the product and the rated voltage., The outside diameter of the plastic collar should not be larger than the pitch (P)

LLF 7.50/04/90V 5.0SN BK BX

Weidmüller Interface GmbH & Co. KG

Klingenbergstraße 26

D-32758 Detmold

Germany

www.weidmueller.com

Technical data

Rated data acc. to IEC

| | | | |
|---|----------------------------------|---|---------|
| tested acc. to standard | In accordance with IEC 60947-7-1 | Rated current, min. number of poles (Tu=20°C) | 41 A |
| Rated current, max. number of poles (Tu=20°C) | 35 A | Rated current, min. number of poles (Tu=40°C) | 41 A |
| Rated current, max. number of poles (Tu=40°C) | 30 A | Rated voltage for surge voltage class / pollution degree II/2 | 1,000 V |
| Rated voltage for surge voltage class / pollution degree III/2 | 1,000 V | Rated voltage for surge voltage class / pollution degree III/3 | 1,000 V |
| Rated impulse voltage for surge voltage class/ pollution degree II/2 | 8 kV | Rated impulse voltage for surge voltage class/ pollution degree III/2 | 8 kV |
| Rated impulse voltage for surge voltage class/ contamination degree III/3 | 8 kV | | |

Rated data acc. to CSA

| | | | |
|-----------------------------------|--------|-----------------------------------|-------|
| Rated voltage (Use group B / CSA) | 600 V | Rated voltage (Use group C / CSA) | 600 V |
| Rated voltage (Use group D / CSA) | 600 V | Rated current (Use group B / CSA) | 35 A |
| Rated current (Use group C / CSA) | 35 A | Rated current (Use group D / CSA) | 5 A |
| Wire cross-section, AWG, min. | AWG 24 | Wire cross-section, AWG, max. | AWG 8 |

Rated data acc. to UL 1059

| | | | |
|---------------------------------------|---|---------------------------------------|--------|
| Institute (cURus) |  | Certificate No. (cURus) | E60693 |
| Rated voltage (Use group B / UL 1059) | 600 V | Rated voltage (Use group C / UL 1059) | 600 V |
| Rated voltage (Use group D / UL 1059) | 600 V | Rated current (Use group B / UL 1059) | 35 A |
| Rated current (Use group C / UL 1059) | 35 A | Rated current (Use group D / UL 1059) | 5 A |
| Wire cross-section, AWG, min. | AWG 24 | Wire cross-section, AWG, max. | AWG 8 |
| Reference to approval values | Specifications are maximum values, details - see approval certificate. | | |

Packing

| | | | |
|-----------|--------|------------|--------|
| Packaging | Box | VPE length | 278 mm |
| VPE width | 207 mm | VPE height | 42 mm |

Classifications

| | | | |
|-------------|-------------|-------------|-------------|
| ETIM 6.0 | EC002643 | ETIM 7.0 | EC002643 |
| ECLASS 9.0 | 27-44-04-01 | ECLASS 9.1 | 27-44-04-01 |
| ECLASS 10.0 | 27-44-04-01 | ECLASS 11.0 | 27-46-01-01 |

LLF 7.50/04/90V 5.0SN BK BX

Weidmüller Interface GmbH & Co. KG
 Klingenbergstraße 26
 D-32758 Detmold
 Germany

www.weidmueller.com

Technical data

Important note

| | |
|----------------|--|
| IPC conformity | Conformity: The products are developed, manufactured and delivered according international recognized standards and norms and comply with the assured properties in the data sheet resp. fulfill decorative properties in accordance with IPC-A-610 "Class 2". Further claims on the products can be evaluated on request. |
| Notes | <ul style="list-style-type: none"> • Additional colours on request • Rated current related to rated cross-section & min. No. of poles. • Wire end ferrule without plastic collar to DIN 46228/1 • Wire end ferrule with plastic collar to DIN 46228/4 • P on drawing = pitch • Rated data refer only to the component itself. Clearance and creepage distances to other components are to be designed in accordance with the relevant application standards. • The test point can only be used as potential-pickup point. • Long term storage of the product with average temperature of 50 °C and average humidity 70%, 36 months |

Approvals

Approvals



UL File Number Search E60693

Downloads

| | |
|---|---|
| Approval/Certificate/Document of Conformity | Declaration of the Manufacturer |
| Engineering Data | STEP |
| User Documentation | QR-Code product handling video |
| Brochure/Catalogue | Catalogues in PDF-format |

LLF 7.50/04/90V 5.0SN BK BX

Weidmüller Interface GmbH & Co. KG
 Klingenbergstraße 26
 D-32758 Detmold
 Germany

www.weidmueller.com

Drawings

Dimensional drawing

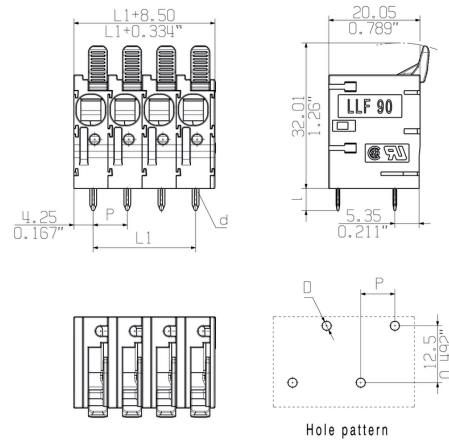

Derating curve

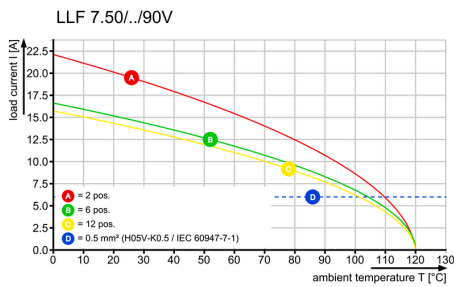

Derating curve

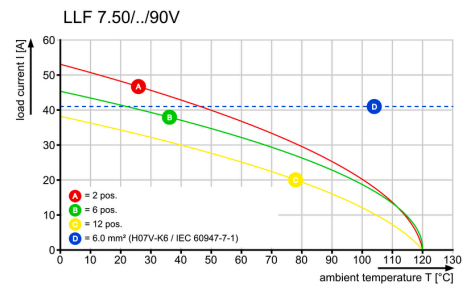

Product benefits

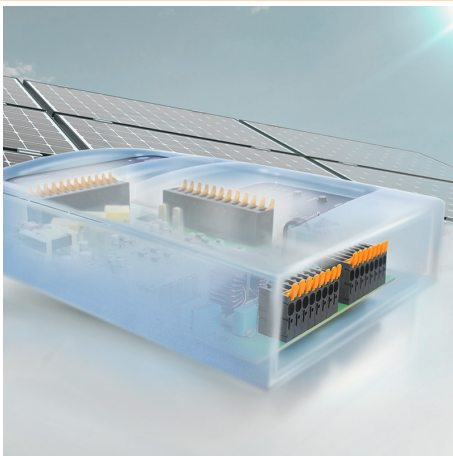

Power up to UL 600 V
 Offset solder pins

Product benefits

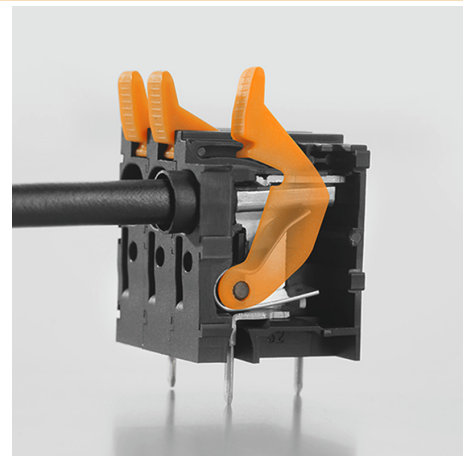

Tool-free wiring
 Top contact security

Data sheet

LLF 7.50/04/90V 5.0SN BK BX

Weidmüller Interface GmbH & Co. KG
Klingenbergstraße 26
D-32758 Detmold
Germany

www.weidmueller.com

Drawings

Product benefits

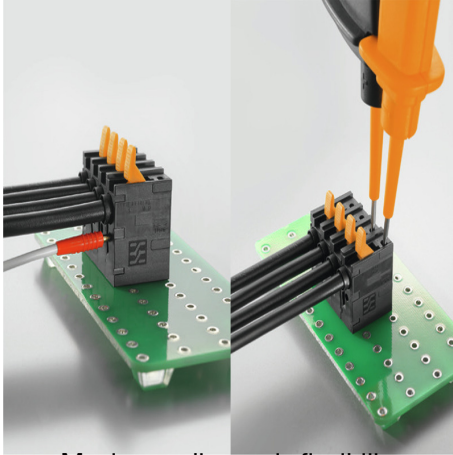

Maximum diagnosis flexibility
Easily accessible test point

General customer drawing, topical version only if required

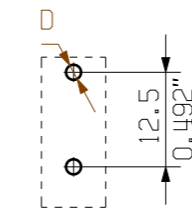
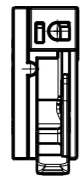
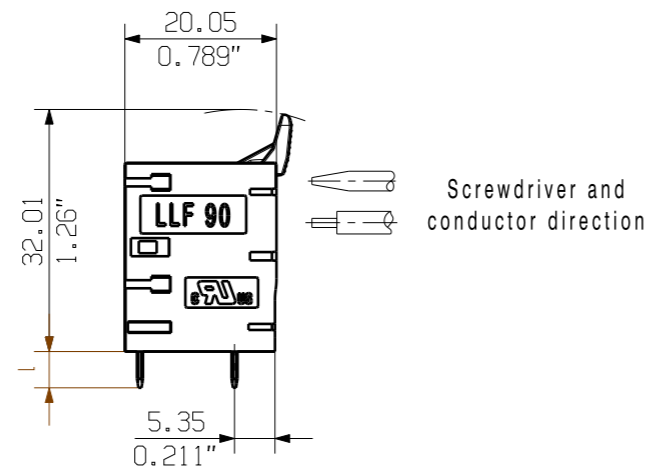
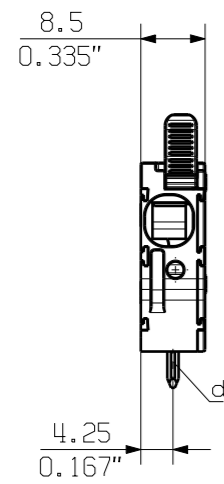

Hole pattern

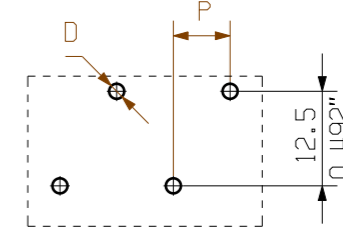
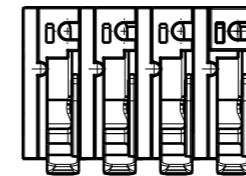
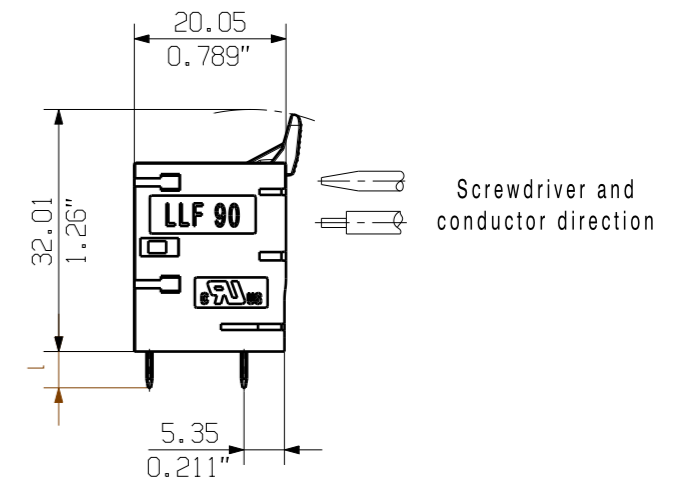
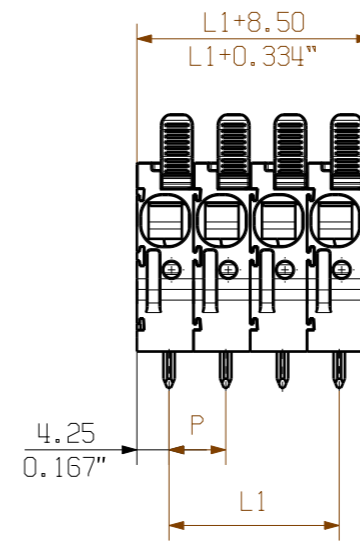
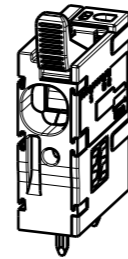

Hole pattern

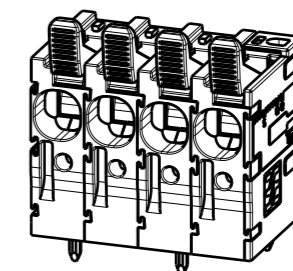

P = 7.50
0.295" (Pitch)
D = Ø2 +0.1
0.079"
d = 1.5x0.8
0.059"x0.031"
l = 5.0 +0.2 -0.6
0.197"

| | | |
|---------|---------|-----------|
| 12 | 82.50 | 3.248 |
| 11 | 75.00 | 2.953 |
| 10 | 67.50 | 2.657 |
| 9 | 60.00 | 2.362 |
| 8 | 52.50 | 2.067 |
| 7 | 45.00 | 1.772 |
| 6 | 37.50 | 1.476 |
| 5 | 30.00 | 1.181 |
| 4 | 22.50 | 0.886 |
| 3 | 15.00 | 0.591 |
| 2 | 7.50 | 0.295 |
| n Poles | L1 [mm] | L1 [inch] |

For the mounting of PCBs, it should be noted that the rated data relates only to the PCB components alone.

The necessary creepage and clearance paths must be observed in connection with the respective applicant in accordance to IEC 664 / VDE 0110.

The current-carrying capacity and pitch tolerance is to be determined according to DIN IEC 326 part 3 very fine.

Weidmüller PCB components are tested to the DIN EN 61984 standard, and are valid for its field of application. Provided that the components are used to the intended purpose, all requirements with respect to the occurring of electrical, mechanical, thermic and corrosive stress will be satisfied.

| | | | | |
|---|-----------------------------------|------------|---|--|
| General tolerance: DIN ISO 2768-mK | 96880/3 02.08.17 DAMERIUS_A | | Cat.no.: . | |
| | Modification | | 3 61339 06 Drawing no. Issue no. | |
| | Drawn | 04.07.2016 | Sheet 01 of 01 sheets | |
| | Responsible | | LLF 7.50/.../90... LEITERPLATTENKLEMME PCB TERMINAL | |
| Scale: 1/1 | Checked | 02.08.2017 | Product file: LLF 7.50 | |
| Supersedes: . | Approved | | 7416 | |

The reproduction, distribution and utilization of this document as well as the communication of its contents to others without explicit authorization is prohibited. Offenders will be held liable for the payment of damages. Weidmüller exclusively reserves the right to file for patents, utility models or designs. © Weidmüller Interface GmbH & Co. KG

Recommended wave soldering profiles

Weidmüller Interface GmbH & Co. KG
 Klängenbergstraße 16
 D-32758 Detmold
 Germany
 Fon: +49 5231 14-0
 Fax: +49 5231 14-292083
 www.weidmueller.com

Single Wave:



Double Wave:



Wave soldering profiles

Wired connection elements should be processed in accordance with the DIN EN 61760-1 standard. We have included two recommendations for practical wave soldering profiles, with which Weidmüller PCB terminals and connectors are qualified.

When choosing a suitable profile for your application, the following factors also need to be considered:

- PCB thickness
- Proportion of Cu in the layers
- Single/double-sided assembly
- Product range
- Heating and cooling rates

The single and double wave profiles each indicate the recommended operating range, including the maximum soldering temperature of 260°C. In practice, the maximum soldering temperature is quite often well below the above maximum profile.